



PRONAR Sp. z o.o.

17-210 NAREW, UL. MICKIEWICZA 101A, PODLASKIE PROVINCE

phone:	+48 085 681 63 29	+48 085 681 64 29
	+48 085 681 63 81	+48 085 681 63 82
fax:	+48 085 681 63 83	+48 085 682 71 10

www.pronar.pl

OPERATOR'S MANUAL

SNOW PLOUGH

PRONAR PUV-2600M / PUV-2800M PRONAR PUV-3000M / PUV-3300M

TRANSLATION OF THE ORIGINAL COPY OF THE MANUAL

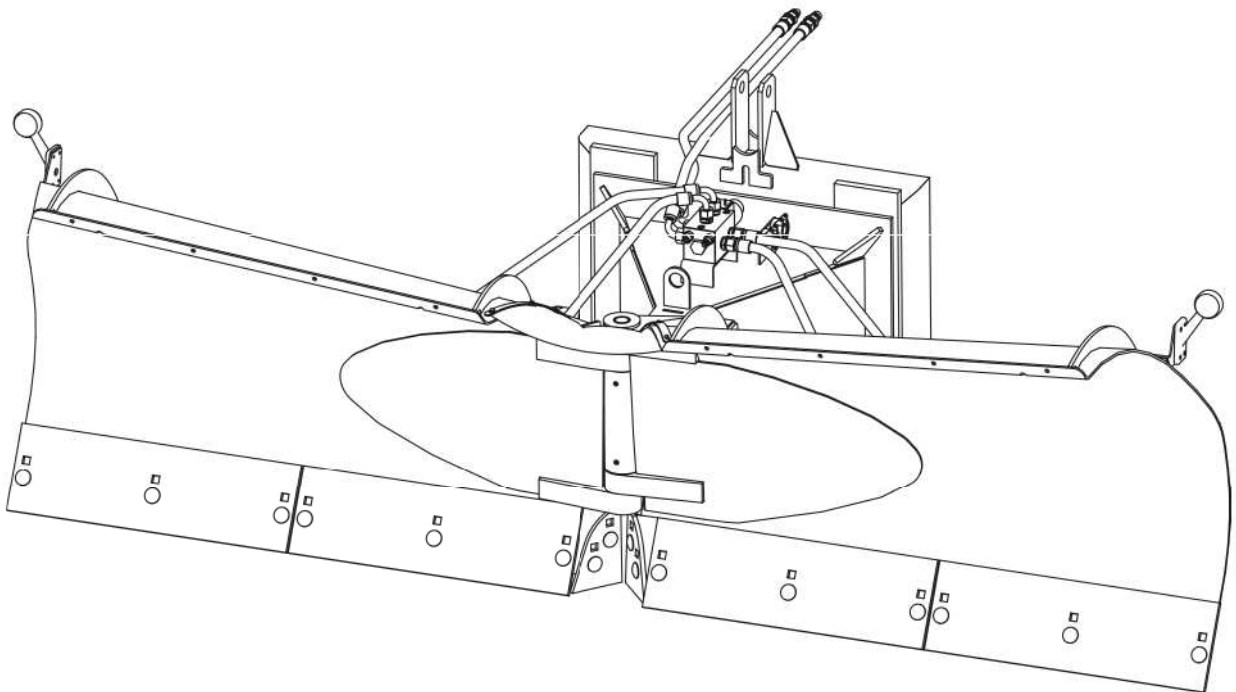

EDITION 1A-09-2014

PUBLICATION NO 446N-00000000-UM



SNOW PLOUGH

PRONAR PUV-2600M / PUV-2800M

PORNAR PUV-3000M / PUV-3300M

MACHINE IDENTIFICATION

TYPE:

SERIAL NUMBER:

--	--	--	--	--	--

INTRODUCTION

Information contained herein is current at date of publication. As a result of improvements, some numerical values and illustrations contained in this publication may not correspond to the factual specification of the machine supplied to the user. The manufacturer reserves the right to introduce design changes in machines produced that facilitate operation and improve the quality of their work, without making minor amendments to this Operator's Manual.

This Operator's Manual is an integral part of the machine's documentation. Before using the machine, the user must carefully read this Operator's Manual and observe all recommendations. This guarantees safe operation and ensures malfunction free work of the machine. The machine is designed to meet obligatory standards, documents and legal regulations currently in force.

The manual describes the basic safety rules and operation of the machine. If the information stated in the Operator's Manual needs clarification then the user should refer for assistance to the sale point where the machine was purchased or to the Manufacturer.

MANUFACTURER'S ADDRESS:

*PRONAR Sp. z o.o.
ul. Mickiewicza 101A
17-210 Narew*

CONTACT TELEPHONES

<i>+48 085 681 63 29</i>	<i>+48 085 681 64 29</i>
<i>+48 085 681 63 81</i>	<i>+48 085 681 63 82</i>

SYMBOLS APPEARING IN THIS OPERATOR'S MANUAL

Information, descriptions of danger and precautions and also recommendations and prohibitions associated with user safety instructions are marked:



and also preceded by the word "**DANGER**". Failure to observe the instructions may endanger the machine operator's or other person's health or life.

Particularly important information and instructions, the observance of which is essential, are distinguished in the text by the sign:



and also preceded by the word "**ATTENTION**". Failure to observe the instructions may lead to damage to the machine as a result of improper operation, adjustment or use.

In order to focus the user's attention on the need to perform maintenance, the relevant section of the Operator's Manual is marked with the pictogram:



Additional tips and advice for machine operation are marked:



and also preceded by the word "**TIP**".

DIRECTIONS USED IN THIS OPERATOR'S MANUAL

Left side – side to the left hand of the operator facing in the direction of machine's forward travel.

Right side – side to the right hand of the operator facing in the direction of machine's forward travel.



PRONAR Sp. z o.o.

ul. Mickiewicza 101 A

17-210 Narew, Polska

tel./fax (+48 85) 681 63 29, 681 63 81, 681 63 82,
681 63 84, 681 64 29

fax (+48 85) 681 63 83

http://www.pronar.pl

e-mail: pronar@pronar.pl

EC DECLARATION OF CONFORMITY OF THE MACHINERY

PRONAR Sp. z o.o. declares with full responsibility, that the machine:

Description and identification of the machinery				
Generic denomination and function:	Snow plough			
Type:	PUV-2600M	PUV-2800M	PUV-3000M	PUV-3300M
Model:	–	–	–	–
Serial number:				
Commercial name:	Snow plough PRONAR PUV-2600M Snow plough PRONAR PUV-2800M Snow plough PRONAR PUV-3000M Snow plough PRONAR PUV-3300M			

to which this declaration relates, fulfills all the relevant provisions of the Directive **2006/42/EC** of The European Parliament and of The Council of 17 May 2006 on machinery, and amending Directive 95/16/EC (Official Journal of the EU, L 157/24 of 09.06.2006).

The person authorized to compile the technical file is the Head of Research and Development Department at PRONAR Sp. z o.o., 17-210 Narew, ul. Mickiewicza 101A, Poland.

This declaration relates exclusively to the machinery in the state in which it was placed on the market, and excludes components which are added and/or operations carried out subsequently by the final user.

Narew, the 2014-10-20

Place and date

Z-CIA DYREKTORA
d/s Technicznych
członek zarządu
Roman Omelianiuk

*Full name of the empowered person
position, signature*

TABLE OF CONTENTS

1	BASIC INFORMATION	1.1
1.1	IDENTIFICATION	1.2
1.2	PROPER USE	1.3
1.3	EQUIPMENT	1.5
1.4	TERMS & CONDITIONS OF WARRANTY	1.5
1.5	TRANSPORT	1.7
1.6	ENVIRONMENTAL HAZARDS	1.9
1.7	WITHDRAWAL FROM USE	1.10
2	SAFETY ADVICE	2.1
2.1	BASIC SAFETY RULES	2.2
2.1.1	USE OF MACHINE	2.2
2.1.2	HITCHING AND UNHITCHING FROM CARRYING VEHICLE	2.3
2.1.3	HYDRAULIC SYSTEM	2.3
2.1.4	TRANSPORTING THE MACHINE	2.4
2.1.5	MAINTENANCE	2.5
2.1.6	MACHINE OPERATION	2.6
2.2	DESCRIPTION OF RESIDUAL RISK	2.6
2.3	INFORMATION AND WARNING DECALS	2.7
3	DESIGN AND OPERATION	3.1
3.1	TECHNICAL SPECIFICATION	3.2
3.2	GENERAL DESIGN	3.3
3.3	HYDRAULIC SYSTEM	3.4
3.4	ELECTRICAL SYSTEM	3.7
4	CORRECT USE	4.1

4.1	PREPARING FOR WORK	4.2
4.2	CHECKING TECHNICAL CONDITION	4.4
4.3	HITCHING TO VEHICLE	4.5
4.3.1	HITCHING TO THE THREE POINT LINKAGE	4.5
4.3.2	HITCHING TO FRONT LOADER OR ANOTHER CARRYING VEHICLE	4.6
4.3.3	CONNECTING THE HYDRAULIC SYSTEM	4.7
4.3.4	CONNECTING THE ELECTRICAL SYSTEM	4.8
4.4	SNOW PLOUGH OPERATION	4.9
4.4.1	LEVELLING THE SNOW PLOUGH BODY	4.9
4.4.2	ADJUSTING THE SNOW PLOUGH WORKING POSITIONS	4.10
4.4.3	SETTING THE WORKING HEIGHT	4.12
4.5	DRIVING ON PUBLIC ROADS	4.14
4.6	UNHITCHING THE MACHINE FROM CARRYING VEHICLE	4.15
5	MAINTENANCE	5.1
5.1	CHECKING AND REPLACEMENT OF COLLECTING BLADES	5.2
5.2	SLIDE REPLACEMENT	5.7
5.3	ADJUSTMENT OF COLLECTING BLADE SPRINGS	5.8
5.4	HYDRAULIC SYSTEM OPERATION	5.9
5.5	ELECTRICAL SYSTEM MAINTENANCE	5.11
5.6	LUBRICATION	5.12
5.7	STORAGE	5.14
5.8	TIGHTENING TORQUE FOR NUT AND BOLT CONNECTIONS	5.15
5.9	TROUBLESHOOTING	5.16

SECTION

1

**BASIC
INFORMATION**

1.1 IDENTIFICATION

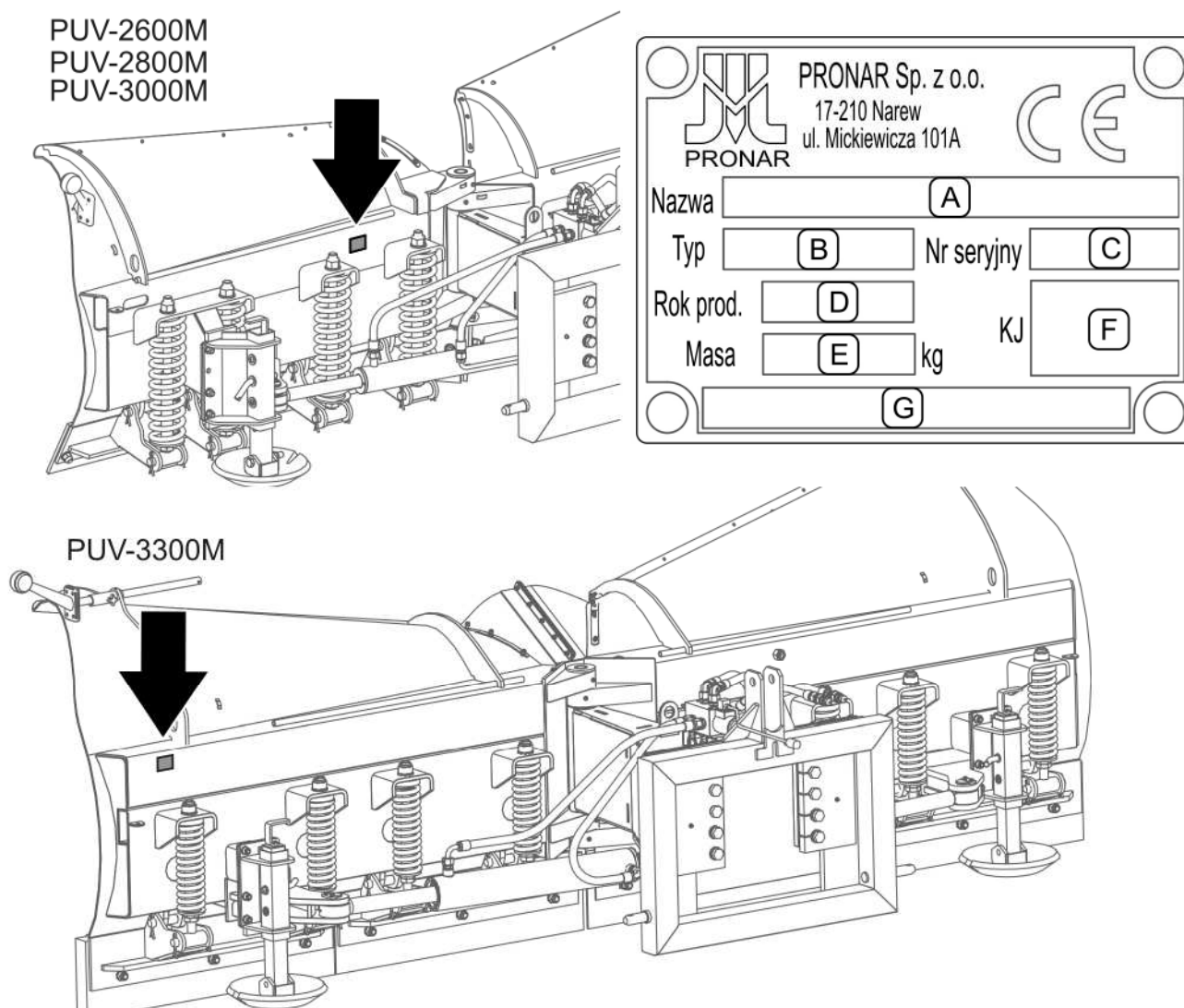

FIGURE 1.1 Location of the data plate

Meaning of data plate items (FIGURE 1.1):

- A - machine name
- B - type
- C - serial number
- D - year of manufacture
- E - machine tare weight [kg]
- F - Quality Control stamp
- G - Unfilled box or extension of name (box A)

The factory number is stamped into the data plate and on mouldboard underneath the data plate. Data plate is located on the left mouldboard of the snow plough. When buying the machine, check that the serial number corresponds with that indicated in the *WARRANTY BOOK*, in the sales documents and in the *OPERATOR'S MANUAL*.

1.2 PROPER USE

The PRONAR PUV-2600M / 2800M / 3000M / 3300M snow ploughs are designed for clearing road surfaces, squares, parking spaces and all other hard road and footpath surfaces such as asphalt, concrete paving blocks, paving, concrete. Use for other purposes should be regarded as improper. Depending on the equipment, the snow ploughs can be mounted on agricultural tractors, front loaders and other slow-moving vehicles that meet the requirements set out in Table 1.1.

Using it as intended also involves all actions connected with the safe and proper operation and maintenance of the machine. Due to the above, the user is obliged to:

- carefully read the *OPERATOR'S MANUAL* and comply with its recommendations,
- understand the machine's operating principle and how to operate it safely and correctly,
- comply with general safety regulations while working,
- prevent accidents,
- comply with road traffic regulations.

The machine may only be used by persons, who:

- are familiar with the contents of this publication and with the contents of the carrying vehicle Operator's Manual,
- have been trained in machine operation and safe working conditions,
- have the required authorisation to drive the vehicle and are familiar with the road traffic regulations and transport regulations.

	<p>IMPORTANT</p> <p>The machine must not be used for purposes other than those for which it is intended, in particular for:</p> <ul style="list-style-type: none"> • levelling of roads, terrain; • transport of people, animals and items on the machine
---	--

TABLE 1.1 Carrying vehicle requirements

		REQUIREMENTS
Electrical system		
Electrical system voltage	V	12
Connection type:		
- control system	-	cigarette lighter socket
- clearance lamps	-	3-pin or 7pin socket (option)
Hydraulic system		
The system pressure range	MPa	16 - 20 *
Hydraulic sockets	-	socket - plug
	-	2 x plug
		of ISO 7241-1 type of one hydraulic section, located on the front of the carrying vehicle
Other requirements		
Mounting method	-	compatible with the snow plough's mounting system
Power range of the carrying vehicle:		
- PUV-2600M/2800M/3000M	hp (kW)	80 - 150 (59 - 110) *
- PUV-3300M	hp (kW)	100 - 200 (74 - 147) *

* - optimum values are given; declared performance and durability of the machine are not guaranteed for other values.

1.3 EQUIPMENT

The snow plough equipment includes:

- Operator's Manual
- Warranty Book

Equipment versions:

- rubber snow plough blades (*vertical ones*)
- steel snow plough blades (*set at the angle of 60° to the ground, with or without bumpers*),
- vertical steel snow plough blades (*set at the angle of 90° to the ground, with or without bumpers*),
- hydraulic system with shock absorbers,
- independent control (*individual control of each mouldboard*),
- *independent-simultaneous control (individual control of each mouldboard or simultaneous control)*,
- hydraulic system equipped with hydraulic socket and plug,
- hydraulic system equipped with two hydraulic conduit connectors,
- slides or supporting wheels
- electric lighting system with a 3-pin or 7-pin plug.

1.4 TERMS & CONDITIONS OF WARRANTY

PRONAR Sp. z o.o., Narew guarantees the reliable operation of the machine when it is used according to its intended purpose as described in the *OPERATOR'S MANUAL*. Defects discovered during the warranty period will be removed by the Warranty Service. The repair period is specified in the *WARRANTY BOOK*.

The warranty does not apply to those parts and sub-assemblies of the machine, which are subject to wear in normal usage conditions, regardless of the warranty period. Consumables include the following parts/sub-assemblies:

- collecting blades,

- supporting wheels, slides,
- light bulbs, fuses

The warranty service only applies to factory defects and mechanical damage that is not due to the user's fault.

In the event of damage arising from:

- mechanical damage which is the user's fault,
- caused by road accidents,
- by inappropriate use, adjustment or maintenance, use of the machine for purposes other than those for which it is intended,
- use of damaged or malfunctioning machine,
- repairs carried out by unauthorised persons, improperly carried out repairs,
- making unauthorised alterations to machine design,

the user will lose the right to warranty service.



TIP

Demand that the seller carefully and precisely fills out the *WARRANTY BOOK* and warranty repair coupons. A missing date of purchase or sale point stamp, may make the user ineligible for any warranty repair or refund.

For detailed Terms & Conditions of Warranty, please refer to the *WARRANTY BOOK* attached to each machine.

Modification of the machine without the written consent of the Manufacturer is forbidden. In particular, do NOT weld, drill holes in, cut or heat the main structural elements, which have a direct impact on the machine operation safety.

1.5 TRANSPORT

The machine is prepared for sale completely assembled and does not require packing.. Packing is only required for the machine operator's manual and electrical system components.

Delivery is either by transport on a vehicle or independently, after being attached to a tractor. Transport of the machine is permissible connected to a carrying vehicle provided the vehicle's driver familiarises himself with the machine's Operator's Manual and particularly with information concerning safety and principles of connection and transport on public roads.

During road transport the machine should be secured on the carrier platform by certified straps or chains fitted with pulley.

When loading and unloading the machine, comply with the general principles of workplace health and safety for reloading work. Persons operating reloading equipment must have the qualifications required to operate these machines.

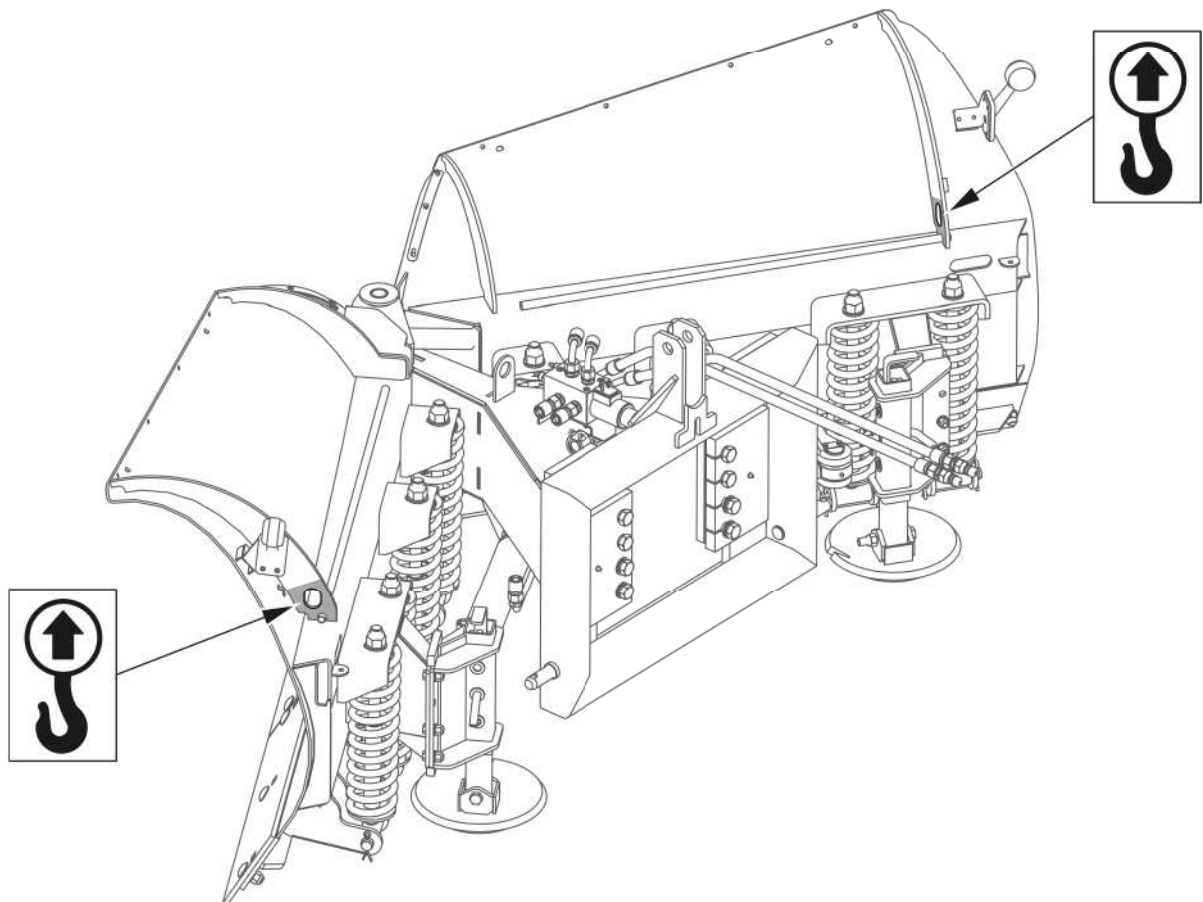



FIGURE 1.2 Transport lugs



ATTENTION

When rising the machine by the transport lugs, the mouldboards should be folded to the rear (FIGURE 1.2)

The machine should be attached to lifting equipment in places specially designed for this purpose (FIGURE 1.2), i.e. by the lugs on the right mouldboard and the left mouldboard. Suspension points are identified with information decals. When lifting the machine take particular care due to the possibility of tipping over the machine and the risk of injuries from protruding parts. To keep lifted machine in the correct direction it is recommended to apply additional guy cables. During the loading work particular care should be taken not to damage paint coating.

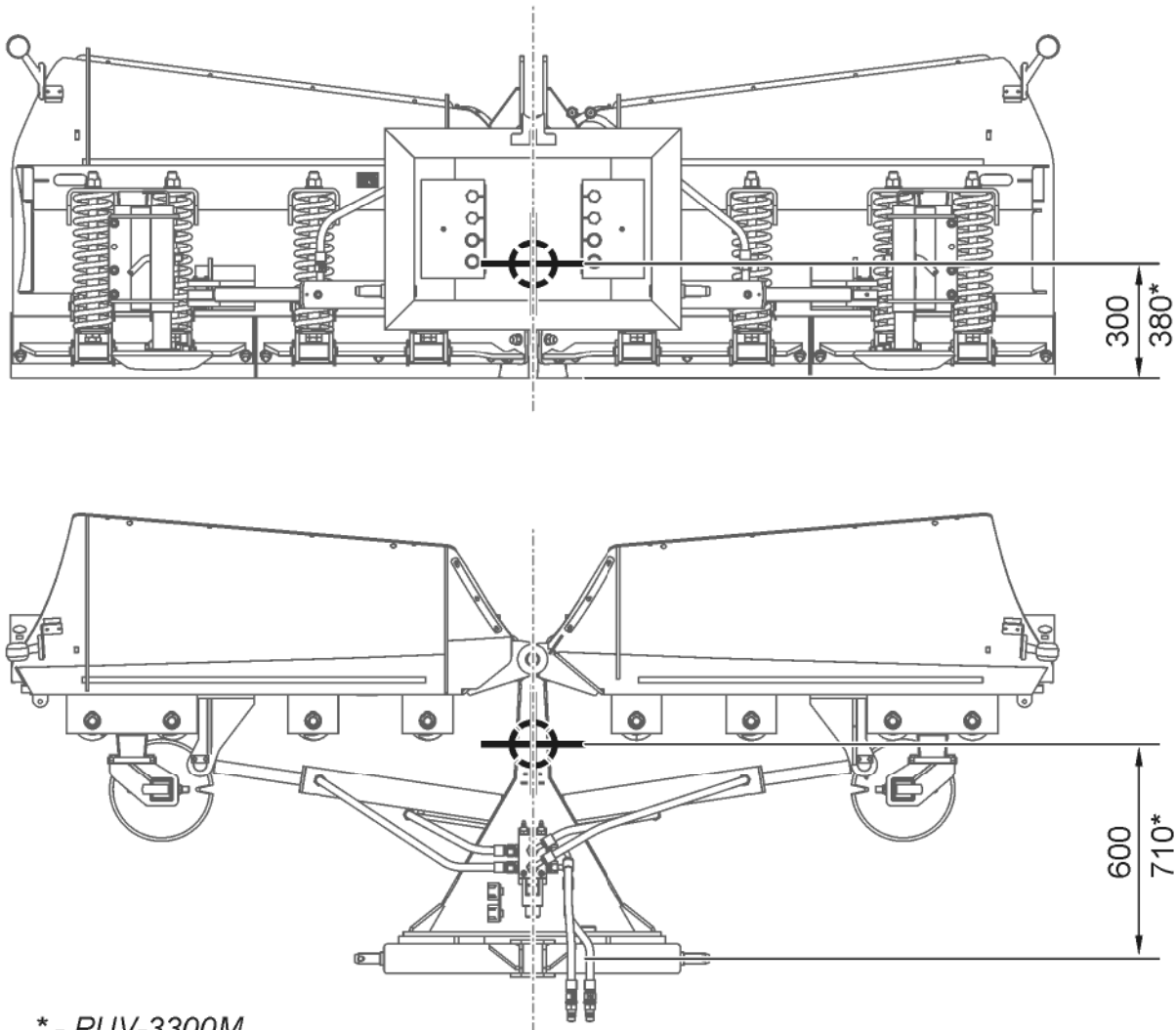

FIGURE 1.3 Centre of gravity

The machine without additional equipment. The mouldboards are set straight.

**ATTENTION**

Depending on the snow plough model and version, the location of its centre of gravity varies within the range of ± 100 mm

**ATTENTION**

Do NOT secure lifting slings or any types of load securing elements to hydraulic and electrical system components and fragile elements of the machine

**DANGER**

When transporting independently, the user must carefully read this Operator's Manual and observe all recommendations. When being transported on a motor vehicle the machine must be mounted on the vehicle's platform in accordance with the transport safety requirements. The driver of the vehicle should take particular care while transporting the machine. This is due to the vehicle's centre of gravity shifting upwards when loaded with the machine.

1.6 ENVIRONMENTAL HAZARDS

A hydraulic oil leak constitutes a direct threat to the natural environment owing to its limited biodegradability. While carrying out maintenance and repair work which involves the risk of an oil leak, this work should take place on an oil resistant floor or surface. In the event of oil leaking into the environment, first of all contain the source of the leak, and then collect the leaked oil using available means. Remaining oil should be collected using sorbents, or by mixing the oil with sand, sawdust or other absorbent materials. The oil pollution, once gathered up, should be kept in a sealed, marked, hydrocarbon resistant container, and then passed on to the appropriate oil waste recycling centre. The container should be kept away from heat sources, flammable materials and food.

Oil, which has been used up or is unsuitable for further use owing to a loss of its properties should be stored in its original packaging in the conditions described above.

1.7 WITHDRAWAL FROM USE

In the event of decision by the user to withdraw the machine from use, comply with the regulations in force in the given country concerning withdrawal from use and recycling of machines withdrawn from use.

Before proceeding to dismantle machine, oil shall be completely removed from hydraulic system.

When spare parts are changed, worn out or damaged parts should be taken to a collection point for recyclable raw materials. Waste oil and also rubber and plastic elements should be taken to establishments undertaking the utilisation of such waste.



IMPORTANT

During dismantling personal protection equipment shall be used i.e. protective clothing, boots, gloves and protective goggles etc.

Avoid contact of skin with oil. Do not allow used oil to spill.

SECTION

2

**SAFETY
ADVICE**

2.1 BASIC SAFETY RULES

2.1.1 USE OF MACHINE

- Before using the machine, the user must carefully read this Operator's Manual and the *WARRANTY BOOK*. When operating the machine, the operator must comply with the recommendations.
- The machine may only be used and operated by persons qualified to drive carrying vehicle and trained in the use of the machine.
- If the information stated in the Operator's Manual is difficult to understand, contact a seller, who runs an authorised technical service on behalf of the Manufacturer, or contact the Manufacturer directly.
- Careless and improper use and operation of the machine, and non-compliance with the recommendations given in this operator's manual is dangerous to your health.
- Be aware of the existence of a residual risk, and for this reason the fundamental basis for using this machine should be the application of safety rules and sensible behaviour.
- The machine must never be used by persons, who are not authorised to drive carrying vehicle, including children and people under the influence of alcohol or other drugs.
- The machine must not be used for purposes other than those for which it is intended. Anyone who uses the machine other than the way intended takes full responsibility for himself for any consequences of this use. Use of the machine for purposes other than those for which it is intended by the Manufacturer may invalidate the warranty.
- The machine may only be used when all the protective elements (i.e. safety guards, bolts, cotter pins) are technically sound and correctly positioned. In the event of loss or destruction of the safety guards, they must be replaced with new ones.

2.1.2 HITCHING AND UNHITCHING FROM CARRYING VEHICLE

- Do NOT hitch the machine to a carrying vehicle, if the linkage system of the machine is not compatible with the linkage system of the carrying vehicle.
- Be especially careful when hitching the machine to carrying vehicle.
- When hitching, there must be nobody between the machine and the carrying vehicle. Exercise caution when unhitching the machine.
- To link the machine to the carrying vehicle use only linking elements envisaged by the Manufacturer.
- The carrying vehicle to which the machine will be coupled must be technically reliable and must fulfil the requirements specified by the machine Manufacturer.
- After completion of hitching the machine, check the safeguards. Carefully read the carrying vehicle Operator's Manual.
- The machine disconnected from the carrying vehicle must be supported on the snowplough blade and slides or wheels (depending on the machine's equipment) and placed on level, sufficiently hard surface in such a manner as to ensure that it is possible to connect it again. The mouldboards should be folded to the rear.

2.1.3 HYDRAULIC SYSTEM

- The hydraulic system is under high pressure when operating.
- Regularly check the technical condition of the connections and the hydraulic lines. There must be no oil leaks.
- In the event of the hydraulic system malfunction, discontinue using the machine until the malfunction is corrected.
- In the event of injuries being caused by pressurised hydraulic oil, contact a doctor immediately. Hydraulic oil may find its way under the skin and cause infections. In the event of contact of oil with eye, rinse with large quantity of water and in the event of the occurrence of irritation consult a doctor. In the event of contact of oil with skin wash the area of contact with water and soap. Do NOT apply organic solvents (petrol, kerosene).

- Use the hydraulic oil recommended by the Manufacturer. Never mix two types of oil.
- Used oil or oil, which has lost its properties, should be stored in original containers or replacement containers resistant to action of hydrocarbons. Replacement containers must be clearly marked and appropriately stored.
- Do not store hydraulic oil in packaging designed for storing food or foodstuffs.
- Hydraulic conduits must be changed every 4 years regardless of their technical condition.
- Repair and replacement of hydraulic system elements should be entrusted to the appropriately qualified persons.

2.1.4 TRANSPORTING THE MACHINE

- When driving on public roads, comply with the road traffic regulations in force in the country, in which the machine is used.
- Do not exceed the permitted speed arising from road conditions and design limitations. Adjust travel speed to the prevailing road conditions and other limitations arising from road traffic regulations limits.
- Do NOT leave the machine raised and unsecured while the carrying vehicle is parked. When parked, the machine should be lowered.
- Do NOT ride on the machine or transport any materials on it.
- Before using the machine always check its technical condition, especially in terms of safety. In particular, check the technical condition of the hitch and hydraulic and electrical system.
- When driving with raised machine, the carrying vehicle's linkage should be locked in the up position to prevent its accidental lowering (if it is possible).
- Reckless driving and excessive speed may cause accidents.

2.1.5 MAINTENANCE

- During the warranty period, any repairs may only be carried out by Warranty Service authorised by the manufacturer. It is recommended that necessary repairs to machine should be undertaken by specialised workshops.
- In the event of any fault or damage whatsoever, do not use the machine until the fault has been corrected.
- During work use the proper, close-fitting protective clothing, gloves and appropriate tools. When working on hydraulic systems it is recommended to use oil resistant gloves and protective goggles.
- Any modification to the machine frees PRONAR from any responsibility for damage or detriment to health which may arise as a result.
- Regularly check the technical condition of the safety devices and correct tightening of bolt connections.
- Regularly perform service inspections of machine as recommended by the Manufacturer.
- Do NOT perform service or repair work under raised and unsupported machine.
- In the event of work requiring the machine to be raised, use properly certified hydraulic or mechanical lifts for this purpose. After lifting the machine, stable and durable supports must also be used. Do NOT carry out work under a machine, which has only been raised with the three point linkage.
- The machine must not be supported using fragile elements (bricks or concrete blocks).
- Servicing and repair work should be carried out in line with the general principles of workplace health and safety. In the event of injury, the wound must be immediately cleaned and disinfected. In the event of more serious injuries, seek a doctor's advice.
- Repair, maintenance and cleaning work should be carried out with the carrying vehicle engine turned off and the ignition key removed. Immobilise the carrying vehicle with parking brake and ensure that unauthorised persons do not have access to the tractor cab.

- Should it be necessary to change individual parts, use only original parts. Non-adherence to these requirements may put the user and other people's health and life at risk, and also damage the machine and invalidate the warranty.
- Do NOT weld, drill holes in, cut or heat the main structural elements, which have a direct impact on the machine operation safety.
- After completing work associated with lubrication, remove excess oil or grease.
- In order to reduce the danger of fire the machine must be kept in a clean condition.

2.1.6 MACHINE OPERATION

- Before lowering or lifting the machine mounted on carrying vehicle make sure there are no bystanders, especially children, near the machine.
- Before starting the machine make sure that there are no bystanders (especially children) or animals in the danger zone. The carrying vehicle operator is obliged to ensure proper visibility of the machine and the working area.
- During machine operation do not occupy a different position than that of the operator in the vehicle's cab. Do NOT leave the cab, when the machine is in operation.
- Person must not stand in the machine operation area and also between the carrying vehicle and the machine.
- Do NOT operate the machine while reversing. While reversing raise the multifunction arm.
- Do NOT use the snow plough with additional ballast.

2.2 DESCRIPTION OF RESIDUAL RISK

Pronar Sp. z o. o. in Narew has made every effort to eliminate the risk of accidents. There is, however, a certain residual risk, which could lead to an accident, and this is connected mainly with the actions described below:

- using the snow plough for purposes other than those for which it is intended,

- being between the carrying vehicle and the machine while the engine is running and when the machine is being attached,
- being on the machine while the engine is running,
- operating the machine with removed or faulty safety guards,
- not maintaining safe distance from the danger zone or being within the zones while the machine is operating,
- operation of the machine by unauthorised persons or persons under the influence of alcohol or other intoxicating substances,
- cleaning, maintenance and technical checks when carrying vehicle is connected and engine is running.





The residual risk may be kept to a minimum by following the recommendations below:



- prudent and unhurried operation of the machine,
- sensible application of the remarks and recommendations stated in the Operator's Manual,
- carrying out repair and maintenance work in line with operating safety rules,
- carrying out repair and maintenance work by persons trained to do so,
- using close fitting protective clothing,
- ensuring unauthorised persons have no access to the machine, especially children,
- maintaining safe distance from forbidden or dangerous places
- a ban on being on the machine when it is operating

2.3 INFORMATION AND WARNING DECALS

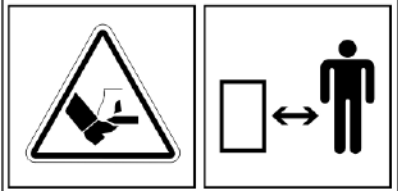
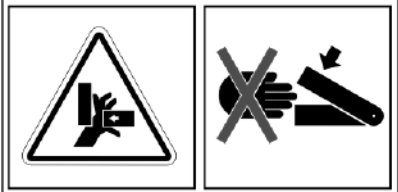
All signs should always be legible and clean, visible to the operator and also to persons possibly being in the vicinity of the machine in operation. If any safety sign is lost or illegible, it should be replaced with a new one. All elements having safety signs replaced during repairs should be affixed with these signs. Safety signs and decals may be purchased from the Manufacturer or the Seller.

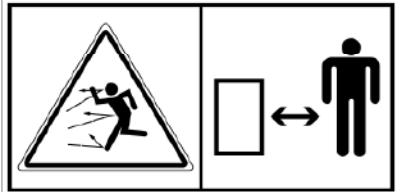
TABLE 2.1 Information and warning decals

ITEM	SYMBOL	DESCRIPTION
1		<p>Before starting work, carefully read the Operator's Manual.</p>
2		<p>When implement is in use there must be no bystanders in designated areas. If any work is required in these areas, make sure the carrying vehicle is stationary, and whether the implement is disconnected from the power source.</p>
3		<p>Risk of injury to foot or leg. Keep a safe distance.</p>
4		<p>Do not reach into crushing space because elements may move. Danger of crushing hands or fingers</p>
5		<p>Pressurised liquid. Keep a safe distance from the operating machine.</p>
6		<p>Danger caused by materials thrown out by the machine. Keep a safe distance from the operating machine.</p>

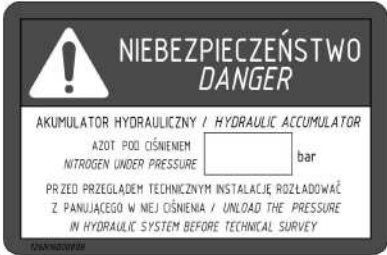
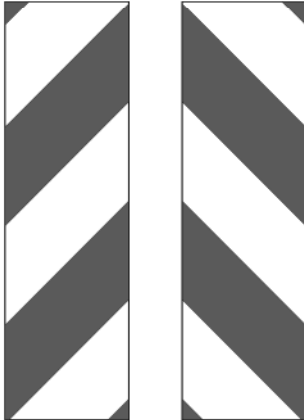
ITEM	SYMBOL	DESCRIPTION
7		Machine model
8		Lifting equipment attachment points while loading the machine
9		<p>Danger. Hydraulic accumulator. Pressurised nitrogen ... bar. Release pressure from the system before the technical inspection.</p> <p><i>* refers to the snow ploughs with hydraulic shock absorbers</i></p>
10		Outline marking.

Numbers in the item column correspond to decals FIGURE 2.1, FIGURE 2.2

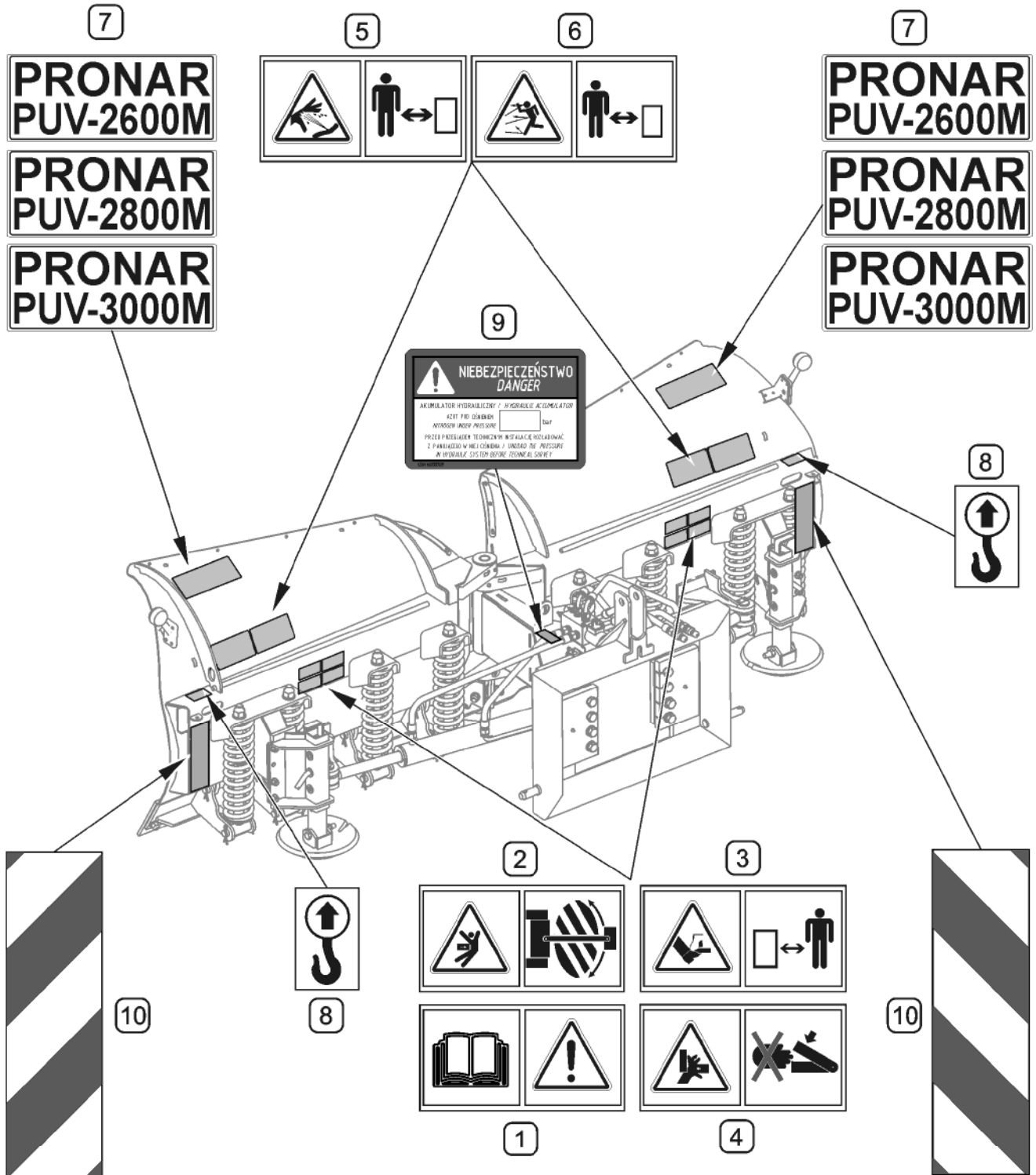

FIGURE 2.1 Locations of information and warning decals (for PUV-2600M / 2800M / 3000M snow ploughs)

Meaning of symbols (TABLE 2.1)

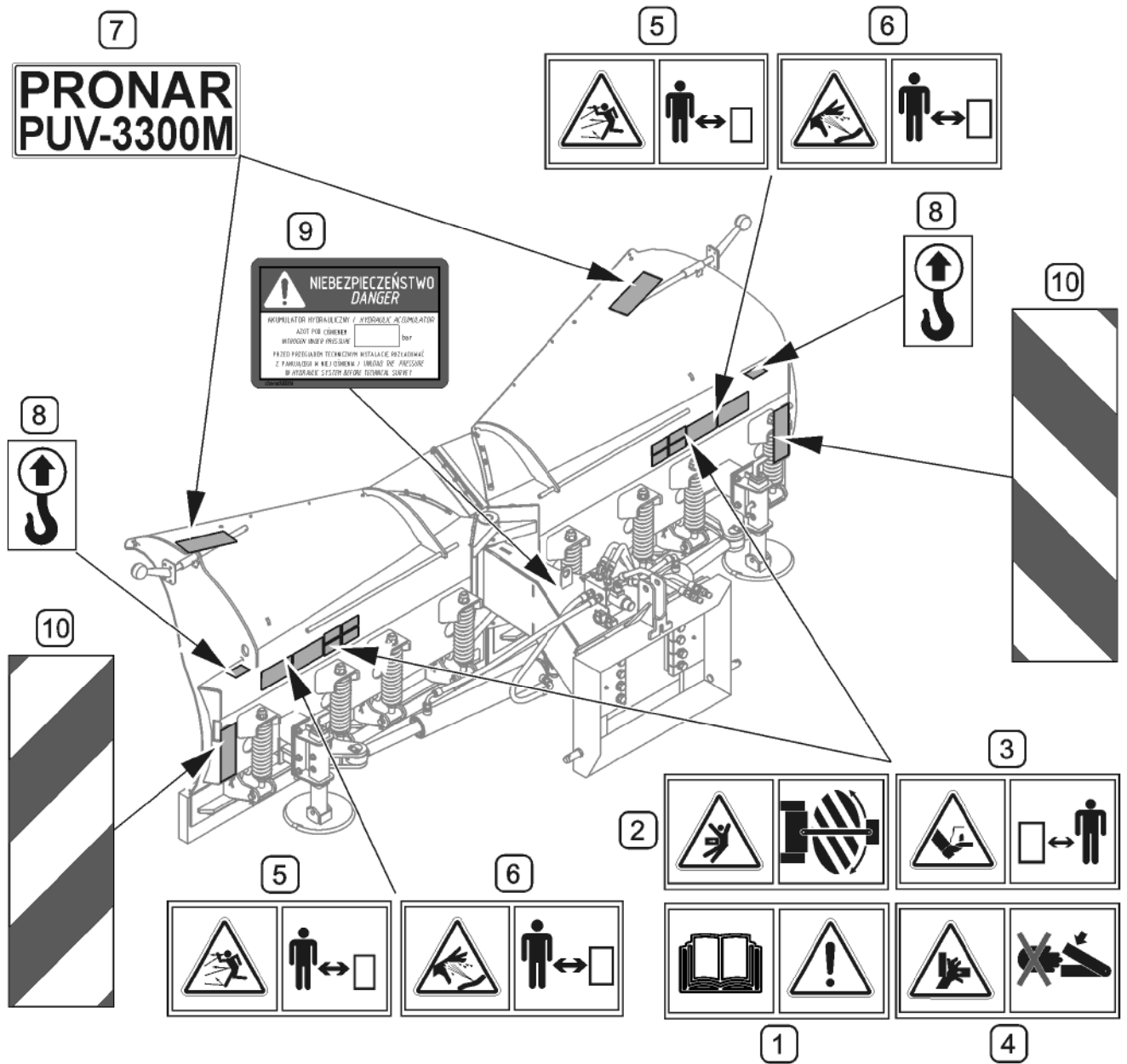

FIGURE 2.2 Locations of information and warning decals (for PUV-3300M)

Meaning of symbols (TABLE 2.1)

SECTION

3

**DESIGN
AND OPERATION**

3.1 TECHNICAL SPECIFICATION

TABLE 3.1 BASIC TECHNICAL SPECIFICATION

	Unit				
Snow plough model	-	PUV-2600M	PUV-2800M	PUV-3000M	PUV-3300M
Working width <i>minimum / maximum</i>	mm	2 075 / 2 640*	2 240 / 2 830*	2 395 / 3 010*	2 570 / 3 305*
Mouldboard height <i>maximum</i>	mm	855	865	880	1,015
Total height	mm	890	900	910	1,070
Total length	mm	1,030	1,130	1,150	1,545
Working angle of mouldboards	°	+ 33° / - 33°		+ 35° / - 35°	
Power supply	-	the electrical system and the external hydraulic system of the carrying vehicle			
Control	-	hydraulic using solenoid			
Electrical system voltage	V	12			
Types of collecting blades	-	<ul style="list-style-type: none"> - rubber blades (<i>perpendicular to the ground</i>) - steel blades (<i>set at the angle of 60° to the ground, with or without a bumper</i>); - steel blades (<i>set at the angle of 90° to the ground, with or without a bumper</i>) 			
Working speed <i>(maximum)</i>	km/h	10 6 - for front loaders			
Weight**	kg	680	700	730	860
Other information	-	single person operation			

* - for the snow plough set perpendicularly to driving direction, steel snow plough blades without bumpers

** - for the machine equipped with steel blades, slides and three-point linkage of cat. II

Level of noise emitted by machine does not exceed 70 dB(A)

3.2 GENERAL DESIGN

The PUV-2600M / 2800M / 3000M / 3300MPUV-3000/PUV-3300 snow ploughs consist of the frame (1) to which the right (3) and left (4) blades are connected by means of the main pin (7). The snow plough is linked to a tractor or other carrying vehicle using a suitable suspension system (2). Rubber or metal blades (5) with shock absorbing springs are able to swing backwards when an obstacle is encountered. The snow plough's functions are managed by means of hydraulic system (8). Depending on the machine version, the snow plough can be equipped with various mounting systems (2) for hitching the snow plough to a wide range of carrying vehicles. Optionally, the snow plough can be equipped with supporting wheels instead of slides.

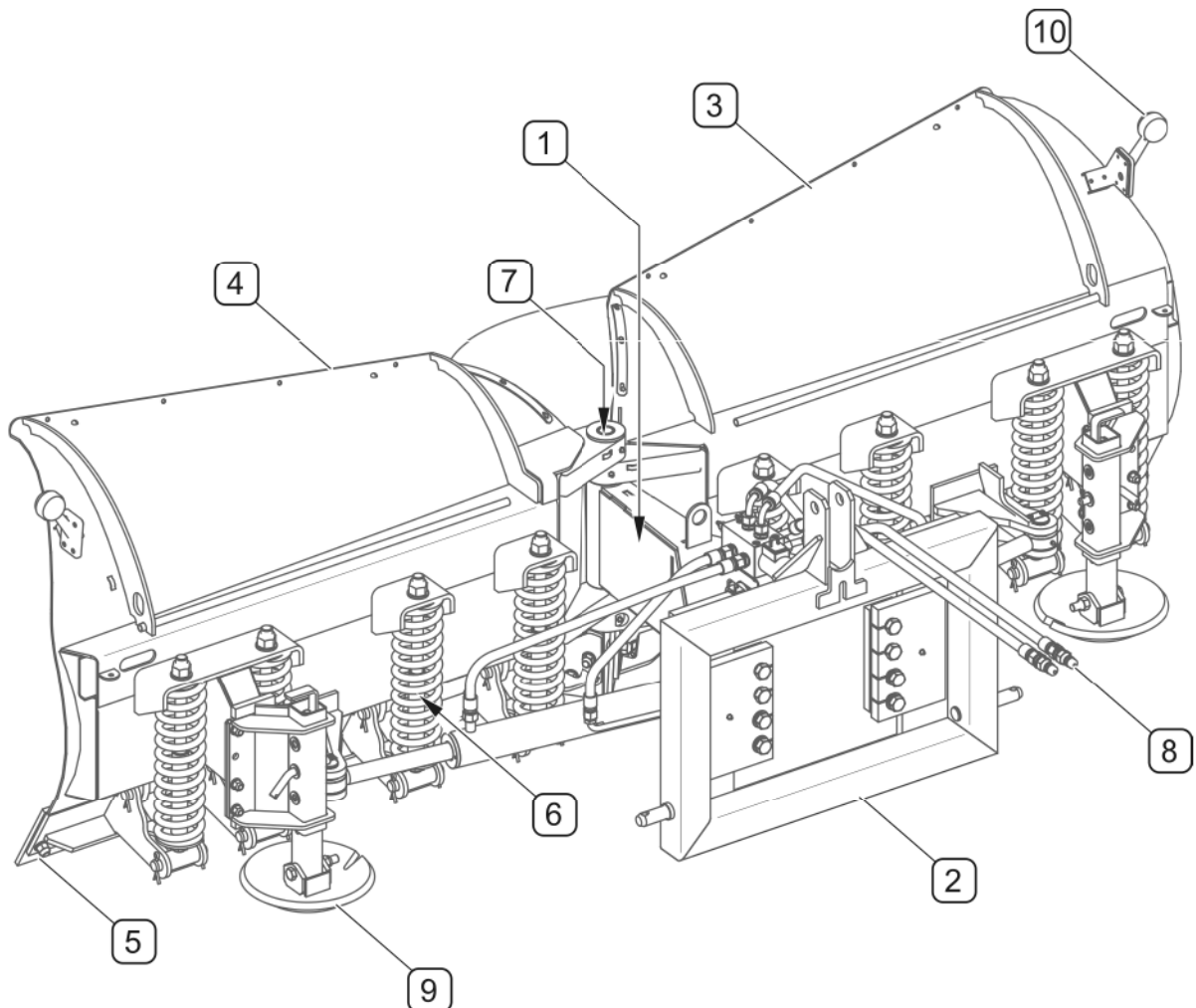

FIGURE 3.1 General design

(1) - frame; (2) - linkage; (3) - right mouldboard; (4) - left mouldboard;
 (5) - tilting collecting blades; (6) - spring; (7) - main pin; (8) - hydraulic system; (9) - slide;
 (10) - electric system

3.3 HYDRAULIC SYSTEM

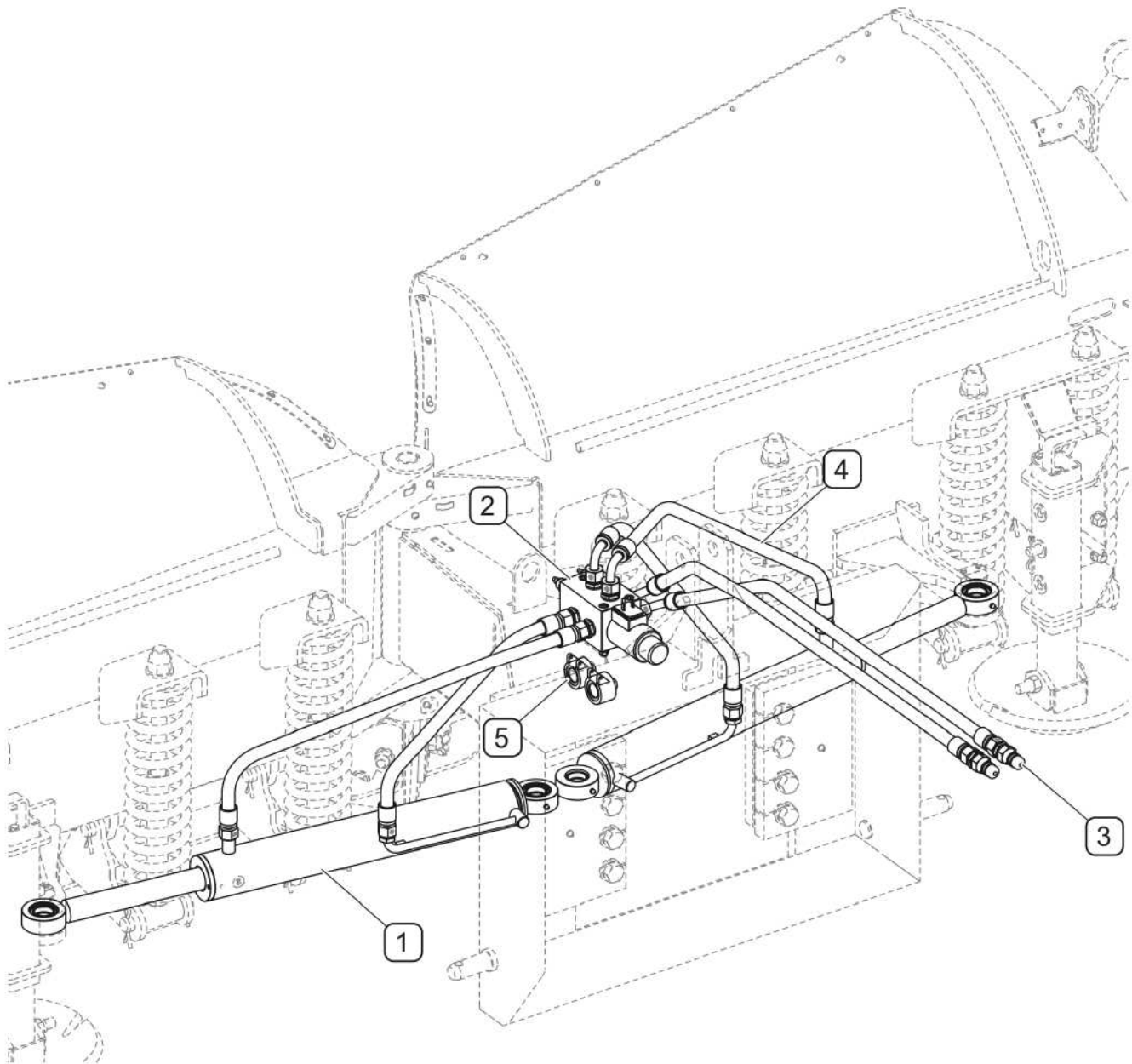

FIGURE 3.2 Hydraulic system design (standard version)

(1) - hydraulic cylinder; (2) - hydraulic solenoid valve; (3) - quick coupler; (4) - conduit; (5) - protection of quick couplers

Working position of the snow plough blades can be adjusted by means of two hydraulic cylinders (1) controlled by solenoid valve (2). The snow plough's hydraulic system is powered with oil supplied from the tractor or loader by two conduits terminated with quick couplings (3). The snow ploughs with hydraulic shock absorbers are also equipped with hydraulic accumulator and solenoid valve with overpressure valve.

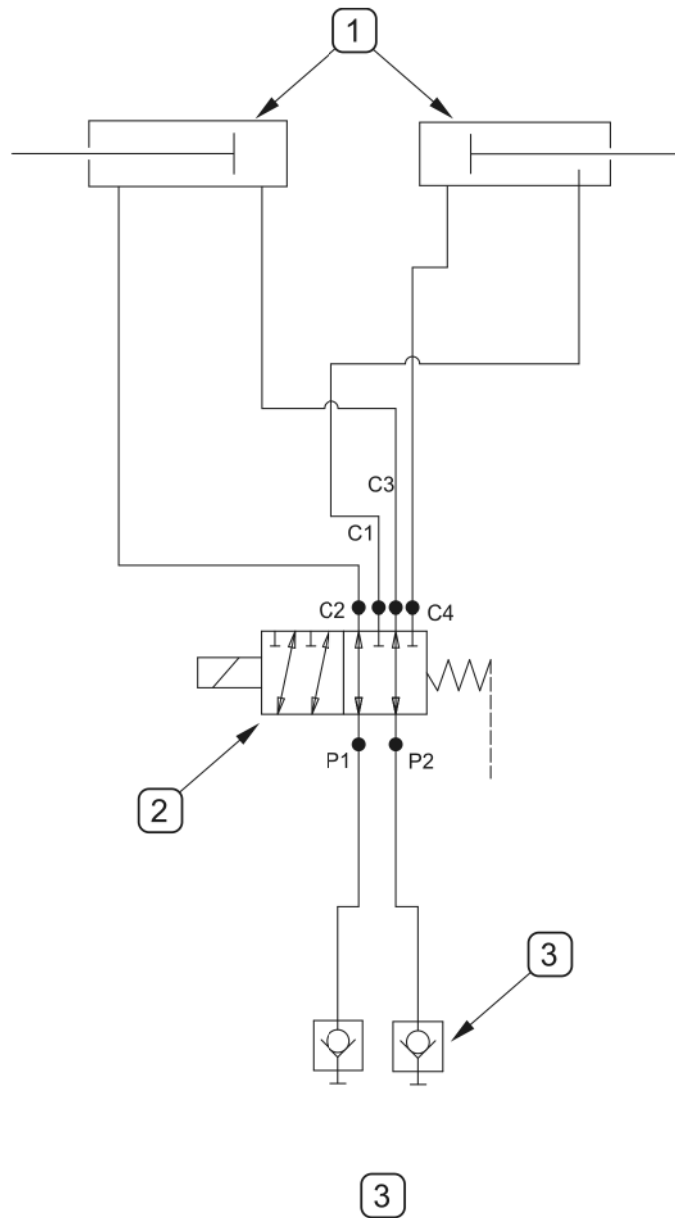

FIGURE 3.3 Concept diagram of the hydraulic system (standard version)

(1) - hydraulic cylinder; (2) - hydraulic solenoid valve; (3) - quick couplers

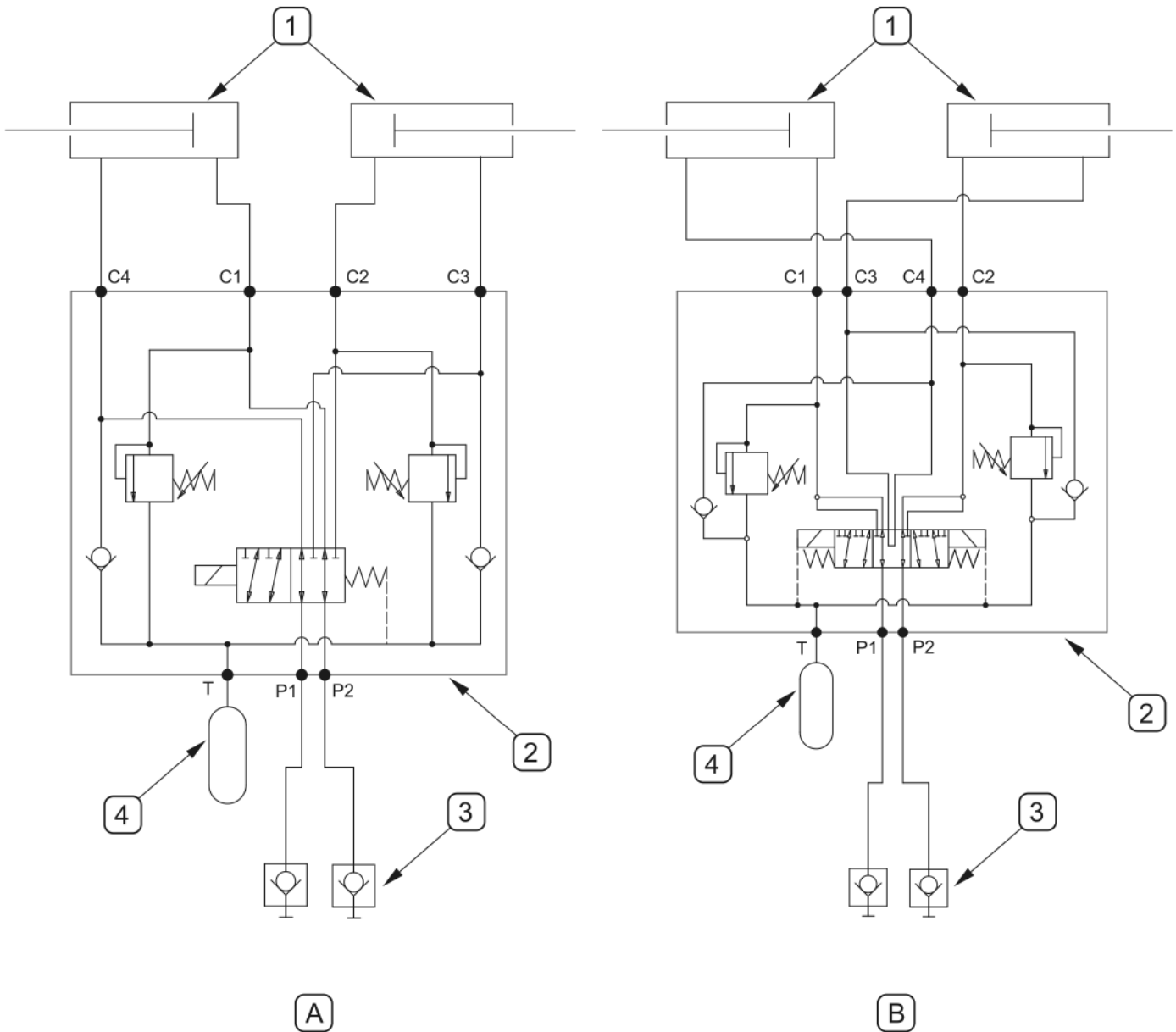

FIGURE 3.4 Concept diagram of the hydraulic system (with hydraulic shock absorbers)

(A) - hydraulic system with hydraulic shock absorbers; (B) - hydraulic system with hydraulic shock absorbers, independent-simultaneous control; (1) - hydraulic cylinder; (2) - hydraulic solenoid valve with overpressure valve; (3) - quick couplers; (4) - hydraulic accumulator

3.4 ELECTRICAL SYSTEM

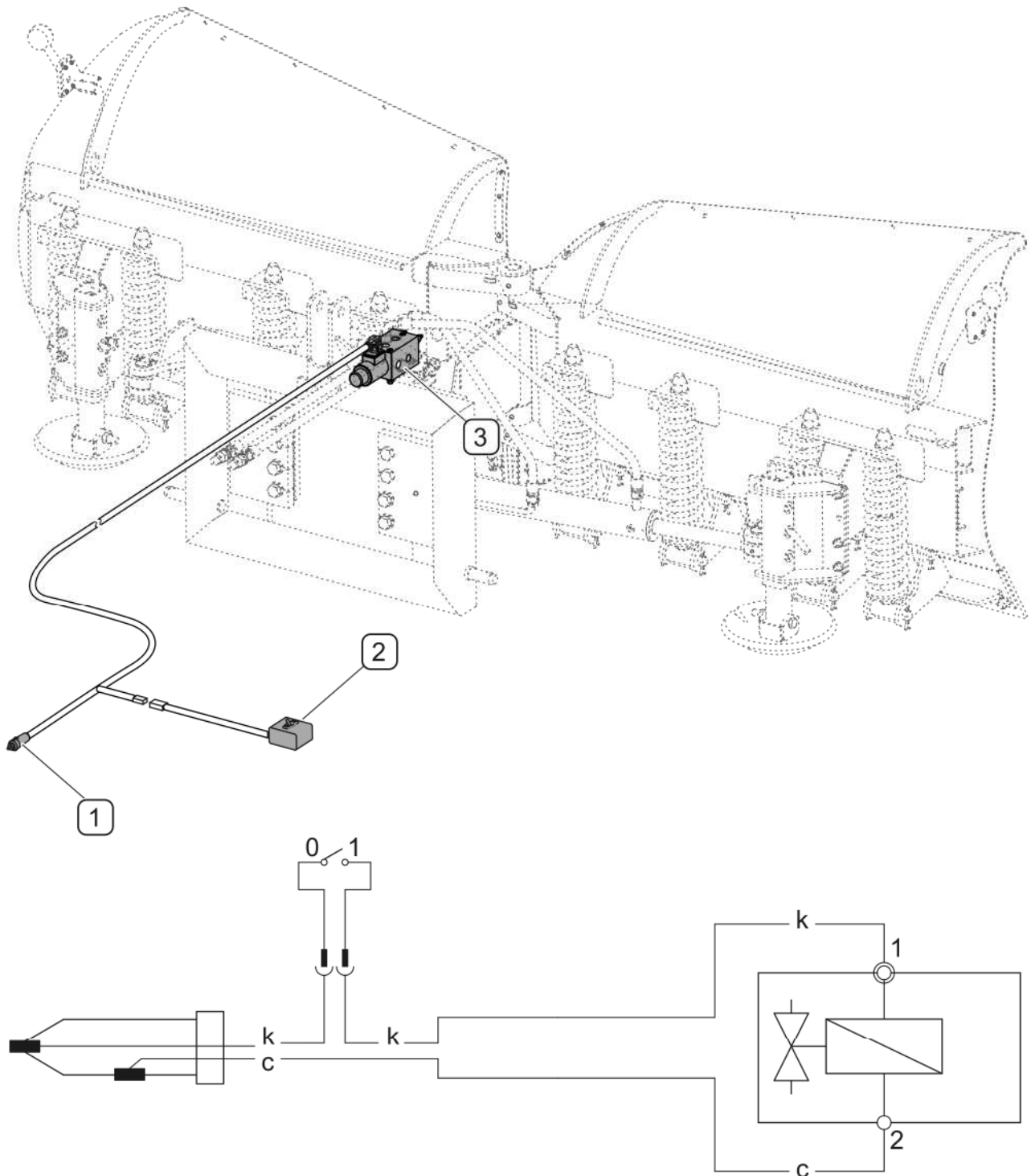

FIGURE 3.5 Design of solenoid valve electrical control system

(1) - cigarette lighter plug; (2) - switch; (3) - solenoid valve;

The electrical system (FIGURE 3.5) is used for controlling the hydraulic solenoid valve (3) and is supplied using 12V cigarette lighter plug from the carrying vehicle's electrical system.

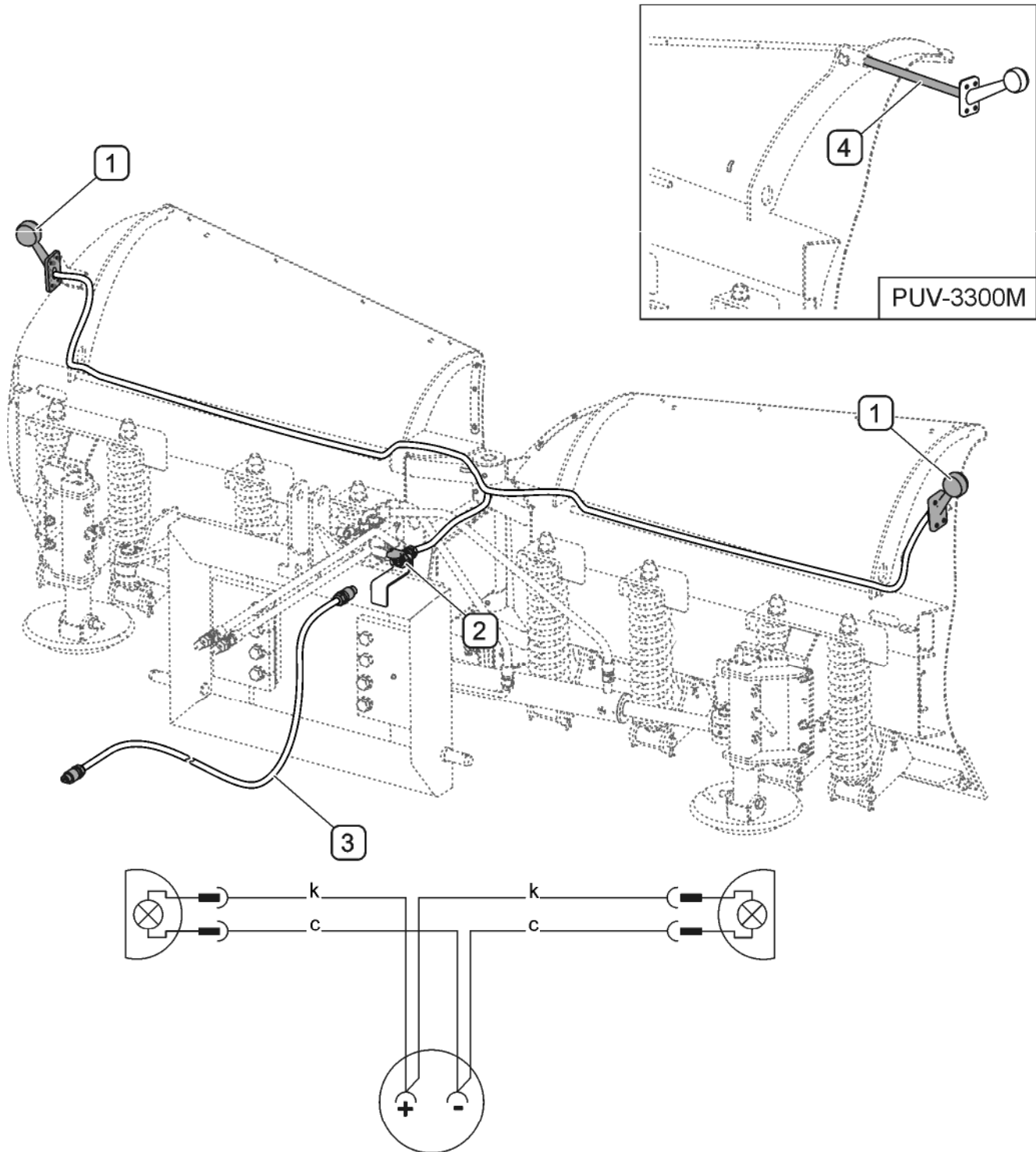

FIGURE 3.6 Design of the clearance lamps electrical system

(1) - clearance lamps; (2) - 3-pin socket; (3) - connecting cable; (4) - adjustable bracket of clearance lamps (only PUV-3300M snow plough)

The electrical system (FIGURE 3.6) is used for supplying the clearance lamps (1) of the snow plough and it is supplied using connecting cable (3) from 3-pin socket or 7-pin socket in the carrying vehicle (depending on machine version).

SECTION

4

**CORRECT
USE**

4.1 PREPARING FOR WORK

DANGER



Before using the machine, the user must carefully read this Operator's Manual.

Careless and improper use and operation of the machine, and non-compliance with the recommendations given in this Operator's Manual is dangerous to your health.

The machine must never be used by persons, who are not authorised to drive carrying vehicles, including children and people under the influence of alcohol or other drugs.

Non-compliance with the safety rules of this Operator's Manual can be dangerous to the health and life of the operator and others.

Before starting the machine, make sure that there are no bystanders in the danger zone.

The manufacturer guarantees that the machine is fully operational and has been checked according to quality control procedures and is ready for use. This does not release the user from an obligation to check the machine's condition after delivery and before first use. The machine is delivered to the user completely assembled (*unless otherwise agreed with the customer*). Prior to connecting to the carrying vehicle, machine operator must verify the machine technical condition. In order to do this:

- the user must carefully read this Operator's Manual and observe all recommendations, understand the design and the principle of machine operation
- check the compatibility of the machine's linkage with the carrying vehicle's linkage,
- make sure that electrical system parameters as well as connection sockets are compatible,
- make sure that hydraulic system parameters as well as connection sockets are compatible,
- check the condition of protective paint coat,
- Inspect machine's individual components for mechanical damage resulting from incorrect transport (dents, piercing, bent or broken components),
- Check all the lubrication points, lubricate the machine according to recommendations provided in section 5 "MAINTENANCE",
- check technical condition of the hydraulic and electrical system;

- check technical condition of mouldboard, collecting blades, slides or supporting wheels,
- check technical condition of the linkage components,



ATTENTION

Non-adherence to the recommendations stated in the Operator's Manual or improper use may cause damage to the machine.

The technical condition before starting the machine must be no cause for concern.

If all the above checks have been performed and there is no doubt as to the machine's good technical condition, it can be connected to carrying vehicle, started and all its individual systems checked. In order to do this:

- hitch the machine to a carrying vehicle (see 4.3 Hitching to carrying vehicle),
- after connecting the electrical and hydraulic system wiring, check the correct operation of individual machine functions and operation of lighting system and inspect tightness of the system and hydraulic cylinders,

In the event of a disruption in the operation of the machine immediately discontinue its use, locate and remove the fault. If a fault cannot be rectified or the repair could void the warranty, please contact the Manufacturer for additional clarifications.



ATTENTION

Before using the machine always check its technical condition. In particular, check the technical condition of the hitch and hydraulic system.

4.2 CHECKING TECHNICAL CONDITION

When preparing the machine for normal use, check individual elements according to guidelines presented in table 4.1

TABLE 4.1 TECHNICAL INSPECTION SCHEDULE

DESCRIPTION	SERVICE OPERATION	FREQUENCY OF INSPECTIONS
Technical condition of mouldboard and collecting blades	Visually inspect and if necessary replace according to section 5 CHECKING AND REPLACEMENT OF COLLECTING BLADES	Before beginning work
Technical condition of slides or supporting wheels (option)	Check technical condition, if complete and correctly mounted.	
Technical condition of the linkage, locking bolts and pins.	Check the technical condition, if complete and correctly mounted.	
Technical condition of the hydraulic system.	Visually inspect the technical condition	
Technical condition of the electrical system and lighting system components (option)	Visually inspect the technical condition, check the operation	
Tightening of all main nut and bolt connections	Torque values should be according to table 5.7	Once a week
Lubrication	Lubricate elements according to chapter „LUBRICATION“.	According to table 5.6



ATTENTION

The machine must not be used when not in working order.

4.3 HITCHING TO VEHICLE

The snow plough can be hitched to a carrying vehicle that meets the requirements contained in Table 1.1 „CARRYING VEHICLE REQUIREMENTS”.

DANGER



Before hitching the machine to carrying vehicle, read the carrying vehicle operator's manual.

When hitching, there must be nobody between the machine and the carrying vehicle. Exercise particular caution.

Depending on machine version, the snow plough can be equipped with a wide range of linkage systems. Before mounting the machine on the carrying vehicle, check the linkage compatibility. The method of hitching the snow plough to the carrying vehicle may differ depending on the type of carrying vehicle.

4.3.1 HITCHING TO THE THREE POINT LINKAGE

DANGER



To hitch the machine to the carrying vehicle use only linking elements recommended by the Manufacturer.

Before hitching the snow plough to tractor three-point linkage, make sure that the category of the tractor linkage is compatible with that of the snow plough.

Hitching the plough to tractor three-point linkage do the following:

- move the lower rod of tractor three-point linkage to the lower linking points of the plough. Set lower rods at an appropriate height,
- switch off tractor's engine and prevent it from moving,
- connect the lower pins of the plough linkage with three-point linkage and secure with cotter pins,
- in the case of the hook linkage place balls on plough linkage pins, secure with cotter pins and lift the pins until balls lock in hooks,
- connect tractor upper link (central connector) to the plough upper attachment point and secure with cotter pin,

- eliminate lateral plough movements by appropriate adjustment of the lower arm stabilisers (if present); it is recommended that both the lower links of the three-point linkage are set at the same height,
- lift the plough using the tractor three point linkage.

**ATTENTION**

Before mounting the machine on the carrying vehicle, check the linkage compatibility.

**ATTENTION**

The connecting cables should be routed so that they do not get entangled in moving machine parts.

4.3.2 HITCHING TO FRONT LOADER OR ANOTHER CARRYING VEHICLE

In order to hitch the snow plough to front loader (FIGURE 4.1):

- unlock quick securing mechanism in loader frame,
- lower arm and turn frame downwards (A) so that mounting points on quick mounting frame are below the mounting points of the plough,
- drive loader close to the plough and insert mounting points in the appropriate places in the quick mounting frame,
- lift the arm (B) so that the upper mounting points are in the plough hooks; controlling the loader frame tilt it back (C), causing the locking of the quick mounting mechanism,
- check if mounting is secure,
- engage the quick securing mechanism (depending on loader type),

The described method of attaching is indicative only and may vary depending on the loader model. A detailed method of connecting attachments is provided in front loader operator's manual.

Prior to hitching the snow plough to another carrying vehicle, the user must carefully read the vehicle (carrying vehicle) operator's manual and observe all Manufacturer's recommendations.

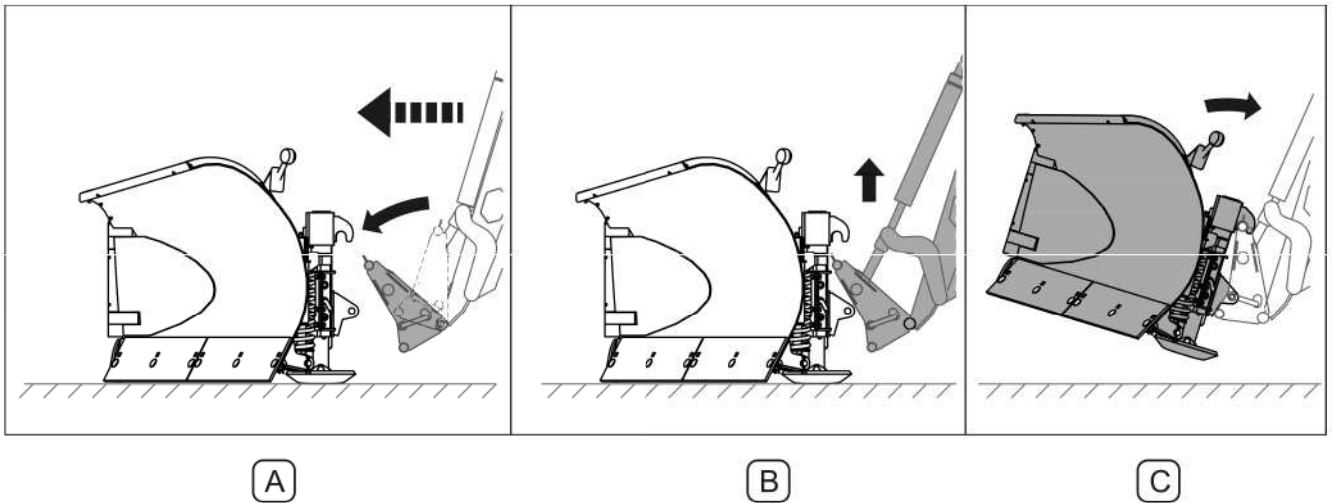

FIGURE 4.1 Hitching to front loader
 (A), (B), (C) - successive stages of hitching

4.3.3 CONNECTING THE HYDRAULIC SYSTEM

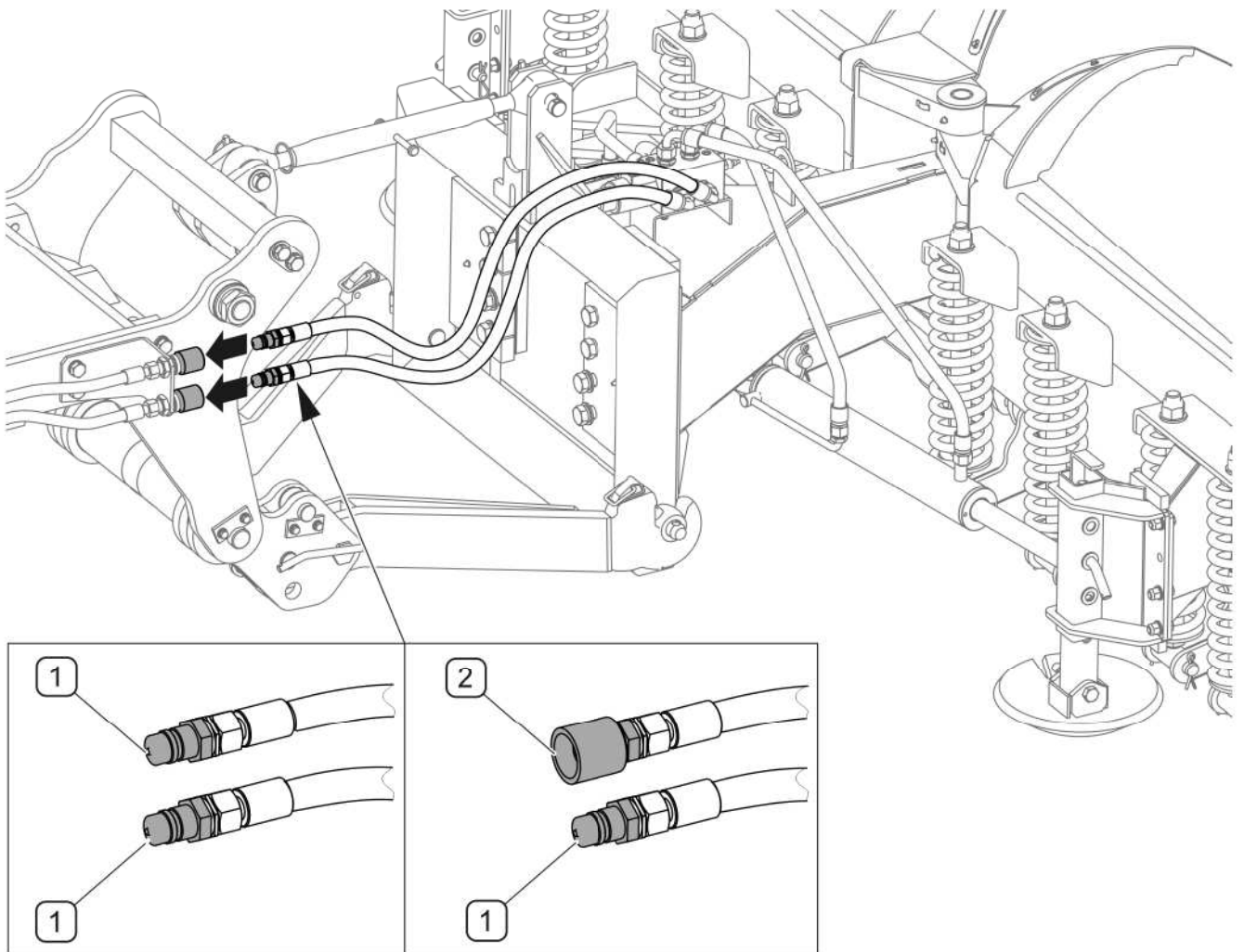



FIGURE 4.2 Connecting the hydraulic system
 (1) - quick coupler plug; (2) - quick coupler socket



DANGER

Reduce pressure in the carrying vehicle's hydraulic system prior to connecting the snow plough's hydraulic system.

The snowplough's hydraulic quick couplers (FIGURE 4.2) should be connected to two connections in one section of the carrying vehicle's external hydraulic circuit. Depending on its version, the machine can be equipped with two hydraulic conduit plugs (1) or a plug (1) and a hydraulic socket (2).

4.3.4 CONNECTING THE ELECTRICAL SYSTEM

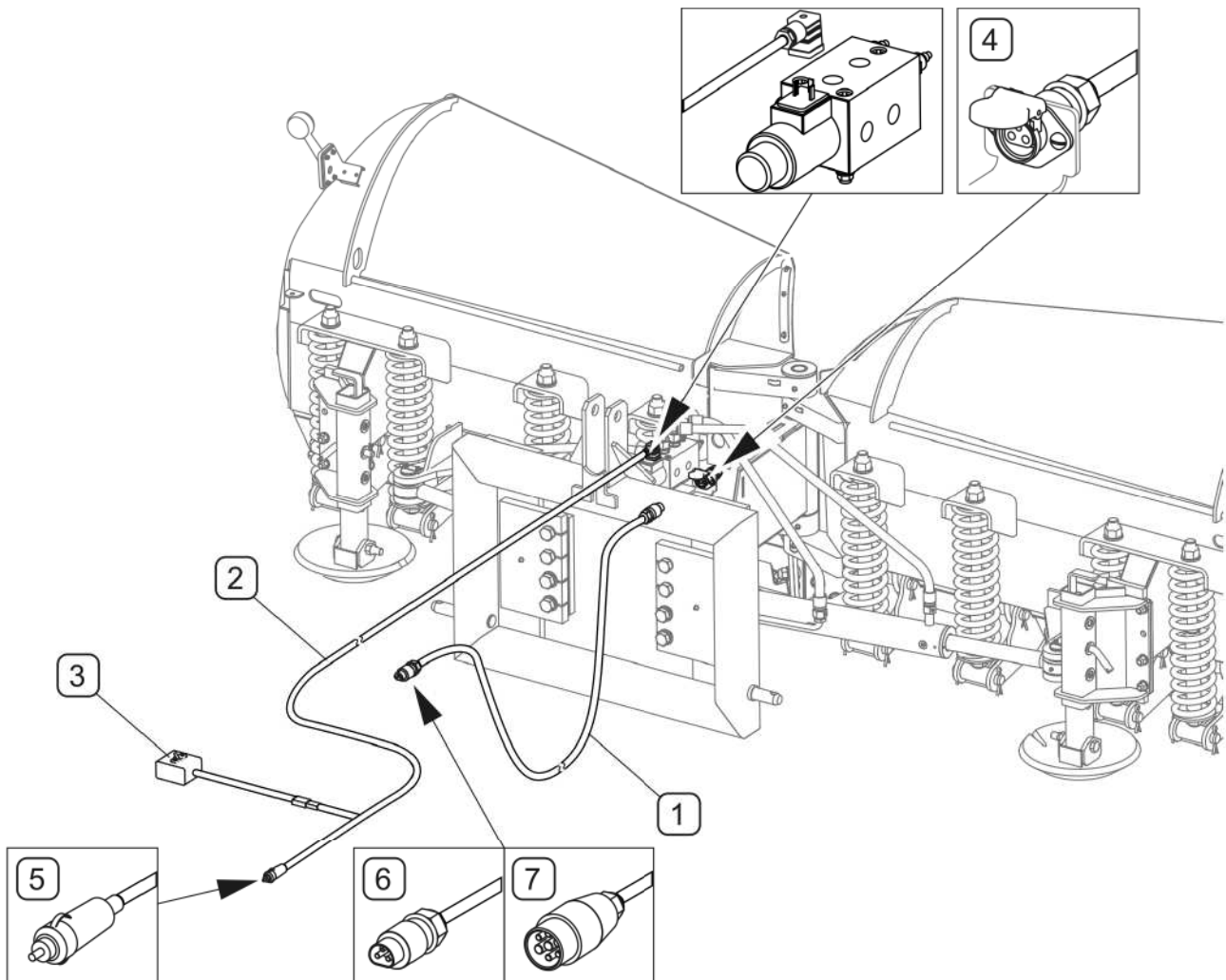

FIGURE 4.3 Connecting the electrical system

(1) - power lead of lighting system; (2) - control lead of hydraulic solenoid valve; (3) - solenoid valve control switch; (4) - 3-pin socket; (5) - cigarette lighter plug; (6) - 3-pin plug; (7) - 7-pin plug (option)

Connect power lead of lighting system (1) (FIGURE 4.3), ended with 3-pin plug (6) to 3-pin socket (4) on the snow plough frame and connect the other end of the lead to 3-pin socket in the carrying vehicle (or to optional 7-pin socket). Connect lead (2) to the snow plough's solenoid valve and to the cigarette lighter socket in the carrying vehicle. Place the switch (3) in an accessible place in the operator cab.

4.4 SNOW PLOUGH OPERATION

4.4.1 LEVELLING THE SNOW PLOUGH BODY

For optimum operation, set the snow plough body at the angle of 90° to the ground surface. Levelling of the snow plough in the carrying vehicles with three-point linkage is done by adjusting the central link (FIGURE 4.4).

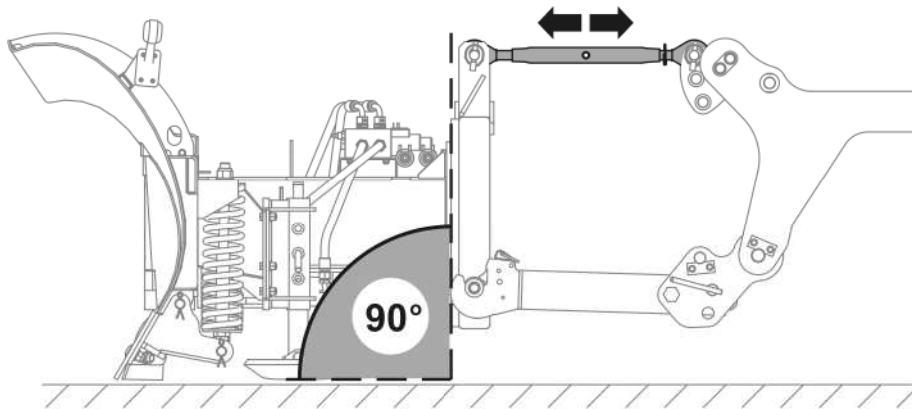

FIGURE 4.4 Levelling the snow plough body suspended on three-point linkage

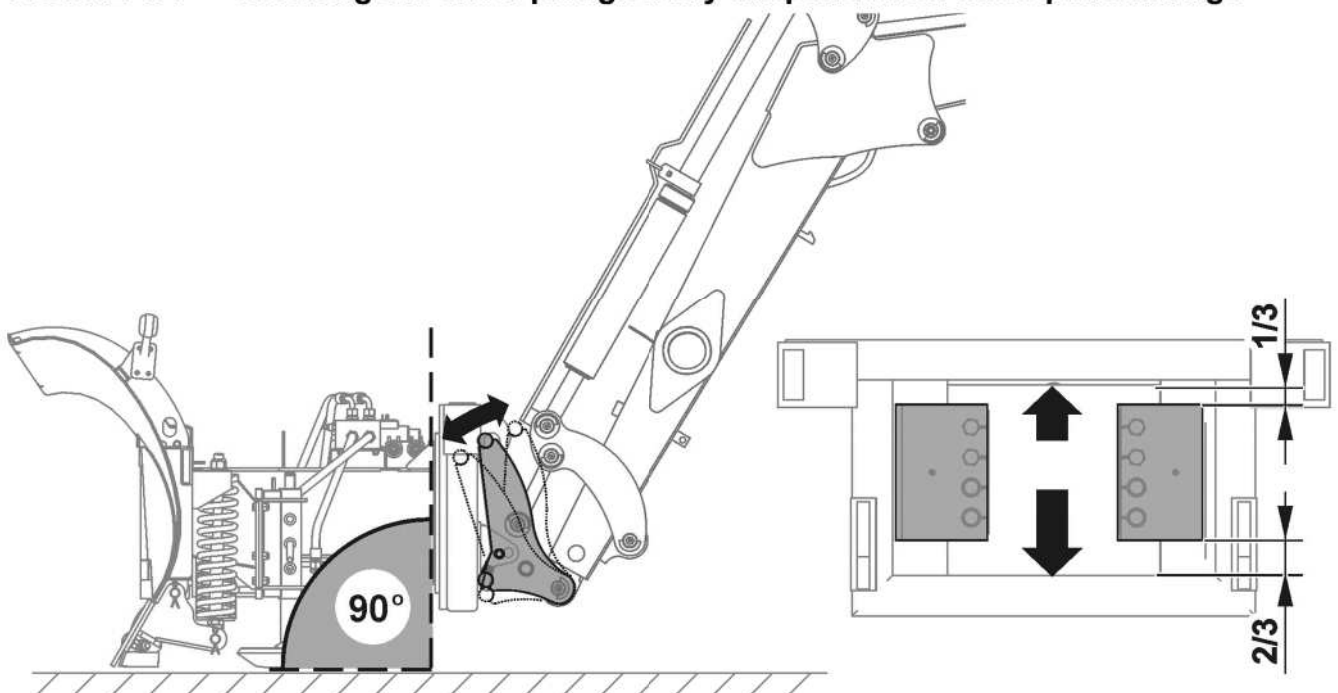

FIGURE 4.5 Levelling the snow plough body on the loader arm

In the carrying vehicles equipped with extension arms (e.g. front loaders), levelling of the snow plough is done by proper positioning of implement mounting frame (FIGURE 4.5)

The swing linkage of the snow plough must be set so that when the snow plough rests on the ground the range of the snow plough body movement relative to the linkage during ground surface tracking is 2/3 down and 1/3 up of the total stroke.

When working with the swing linkage plough, make sure that the carrying vehicle linkage is fixed; do not work in a floating position. The carrying vehicle's extension arm must not exert load on the plough during work.

4.4.2 ADJUSTING THE SNOW PLOUGH WORKING POSITIONS

The snow plough has four adjustable working positions. In order to change the snow plough working position use the switch and the hydraulic system manifold lever that controls a relevant section of the external hydraulic system of the carrying vehicle.

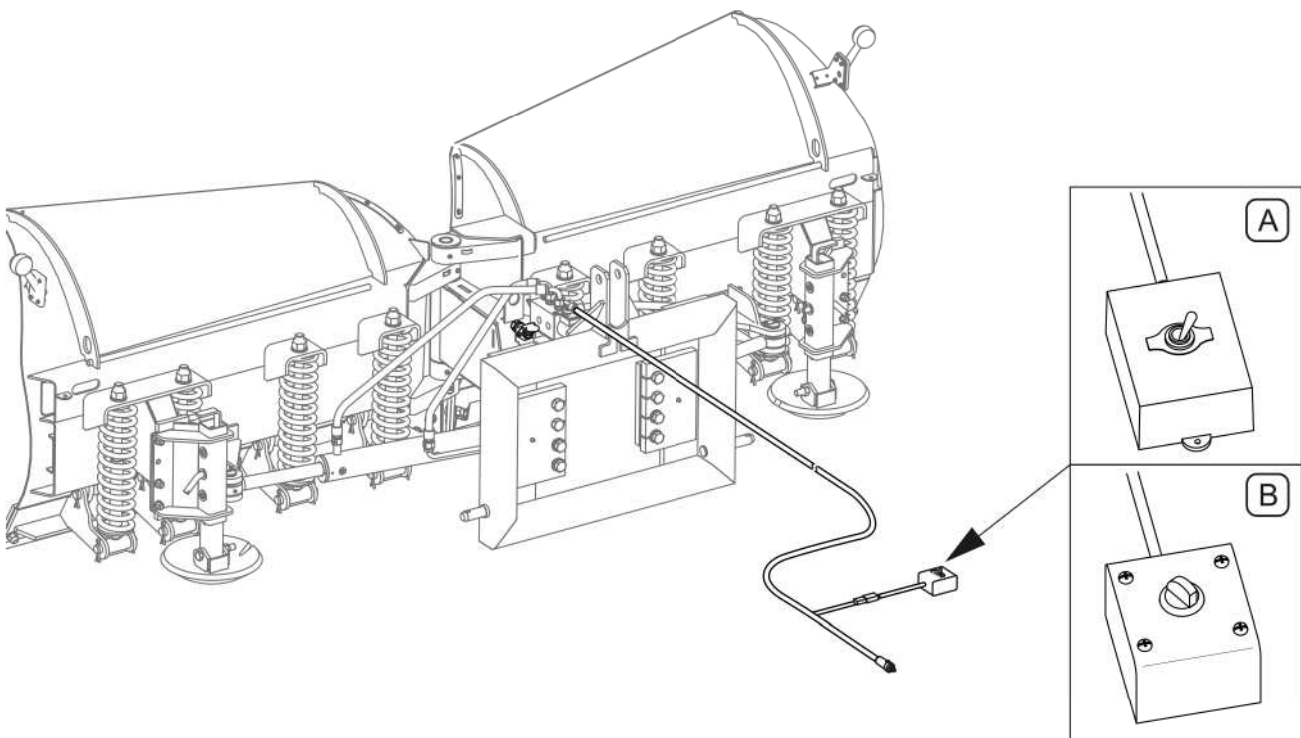

FIGURE 4.6 Control switch of the snow plough working position

(A) - 2-position independent control switch; (B) - 3-position independent-simultaneous control switch

Depending on type of control system (FIGURE 4.6) (independent or independent-simultaneous control), the snow plough can be equipped with 2-position switch (A) or 3-position switch (B).

The snow plough equipped with independent control system (A) has a 2-position switch (ON-OFF). Depending on the switch position (ON or OFF), the hydraulic system can control alternately the right or the left snow plough wing.

The snow ploughs equipped with independent-simultaneous control system (B) has a 3-position switch (0-1-2). If the switch is set to position (1) or (2), the hydraulic system can control alternately the right or the left snow plough wing. If the switch is set to position (0), the right and the left snow plough wings can be controlled simultaneously.

**DANGER**

When the machine is in use there must be no bystanders near the machine.

**IMPORTANT!**

It is not recommended to operate the machine in heavy duty conditions with a speed exceeding 6 km/h.

Working speed of the machine depends on the type and quantity of collected material but also on the type of terrain. It is not recommended to operate the snow ploughs mounted on front loaders when blades are set (to the right or to the left) in severe conditions, i.e.:

- on uneven terrain,
- in unknown terrain with obstacles
- on packed or frozen snow or ice,
- on snow layer thicker than 30 cm.

**IMPORTANT!**

Hydraulic system with shock absorber is recommended for work in severe conditions.

**IMPORTANT!**

Do NOT operate the plough while reversing. While reversing raise the machine.

4.4.3 SETTING THE WORKING HEIGHT

The slides or wheels are used in order to maintain a proper distance between the ground and collecting blades, to reduce thickness of scraped material layer and to limit the depth of blade sinking into soft ground.



DANGER

Setting the working height should be performed only when the engine is stopped, and the machine is raised and secured.

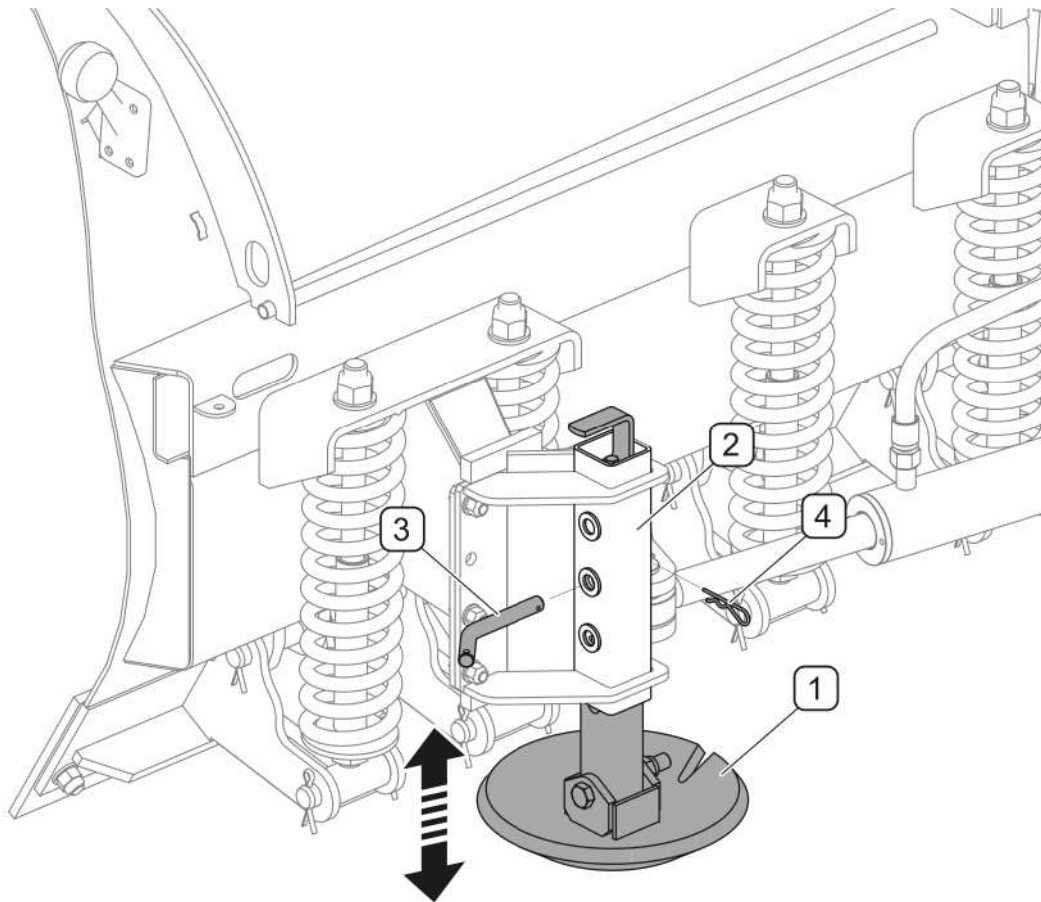

FIGURE 4.7 Height adjustment in ploughs equipped with slides.

(1) - slide, (2) - slide guide (3) - pin, (4) - locking cotter pin

In ploughs equipped with slides (FIGURE 4.7), the height adjustment is performed by unlocking pin (4) and proper sliding out or sliding in the slide (1) mounted in guide (2). Location of the slide in the guide can be changed every 7 mm using one of the three openings in the guide. When the height is set, slides must be protected with a pin (3) and spring cotter pin (4). Slides of the left and right mouldboard should be put forward at the same height.

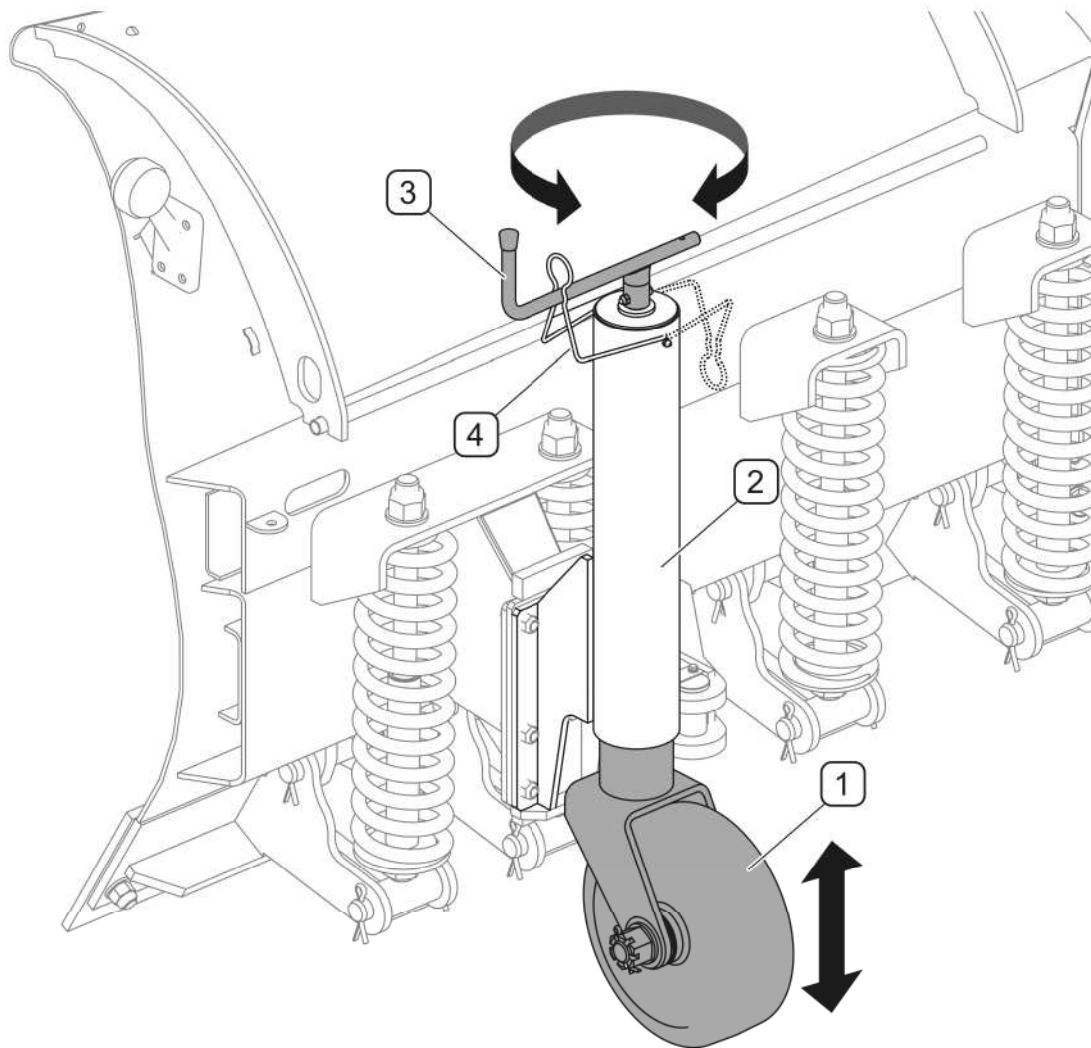

FIGURE 4.8 Height adjustment in ploughs equipped with wheels

(1)- wheel; (2)- body; (3)- knob; (4)- knob lock

In ploughs equipped with supporting wheels (FIGURE 4.8), the height adjustment is performed by withdrawal or insertion of wheel (1) in the body (2) by turning the knob (3). The handle is protected by a lock (4). After setting the wheel height, appropriately set handle (3) and secure it with lock (4). It is recommended that both wheels are set at the same height.

4.5 DRIVING ON PUBLIC ROADS

When driving on public roads, respect the road traffic regulations, exercise caution and prudence. If the clearing with machine is done on a pavement or promenade special attention should be paid to the bystanders likely to be near the working machine. Listed below are the key guidelines.

- Before moving off make sure that there are no bystanders, especially children, near the machine and the carrying vehicle. Take care that the driver has sufficient visibility.
- Make sure that the machine is correctly attached to the carrying vehicle, and linkage is properly secured.
- The maximum working speed and the maximum speed allowed by road traffic regulations must not be exceeded. Speed of travel should be adjusted to prevailing road conditions and other conditions.
- While driving on public roads turn on the lights.
- While working with the snow plough, turn on the orange beacon light (included in the carrying vehicle equipment).
- Avoid ruts, depressions, ditches or driving on roadside slopes. Driving across such obstacles could cause the machine and the carrying vehicle to suddenly tilt. Driving near ditches or canals is dangerous as there is a risk of the slope collapsing.
- Speed must be sufficiently reduced before making a turn or driving on an uneven road or a slope.
- When driving on uneven terrain with the plough raised reduce speed due to dynamic loads and the risk of damaging the machine or carrying vehicle.
- Set properly the brackets of the snow plough's clearance lights (only PUV-3300M).

4.6 UNHITCHING THE MACHINE FROM CARRYING VEHICLE



DANGER

Reduce pressure prior to disconnecting the hydraulic system.

In order to disconnect the plough from the carrying vehicle, proceed as follows:

- position the snow plough so that the wings are folded to the rear,
- lower the snow plough until it fully rests on the ground,
- turn off the carrying vehicle's engine, engage the parking brake,
- reduce residual pressure in the hydraulic system by movement of appropriate lever controlling hydraulic circuit,
- disconnect hydraulic conduit plugs from the carrying vehicle and electric power leads of the solenoid valve and clearance lights,
- hydraulic conduit quick couplers must be protected against contamination and inserted in special sockets on the snow plough frame,
- disconnect the snow plough from the carrying vehicle's linkage,
- after disconnecting from the carrying vehicle, the snow plough should rest on the ground leaning against collecting strips and slides or supporting wheels (option).

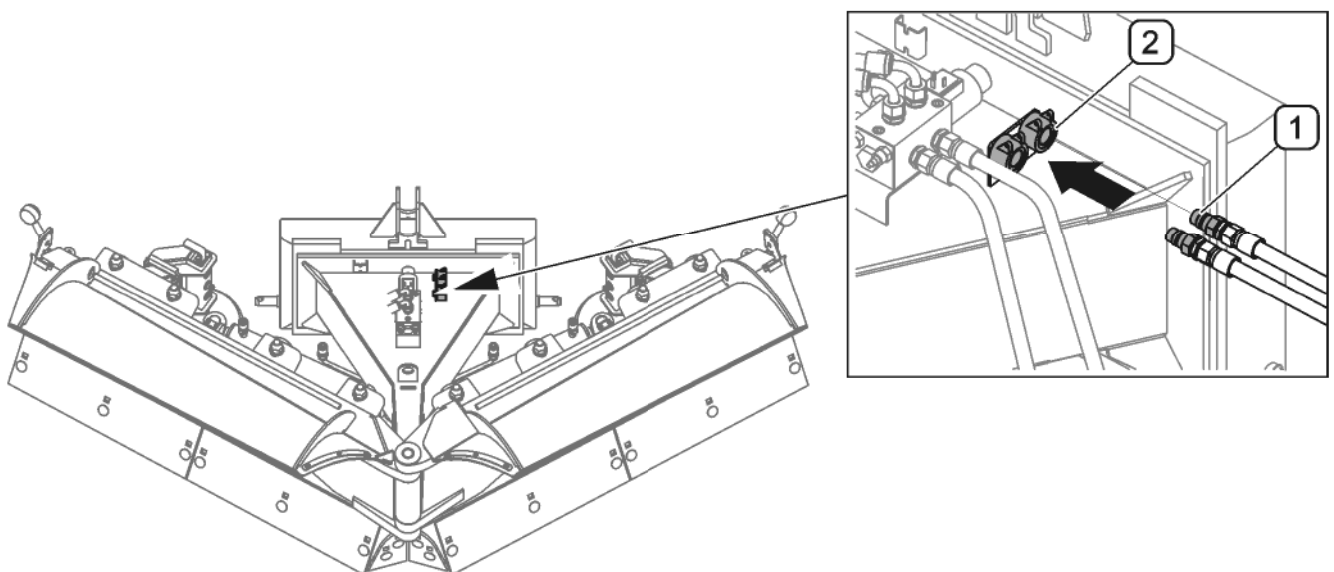

FIGURE 4.9 Protection of hydraulic conduit quick couplers

(1) - hydraulic conduit quick coupler; (2) - securing socket

SECTION

5

MAINTENANCE

5.1 CHECKING AND REPLACEMENT OF COLLECTING BLADES



DANGER

During inspection and replacement of the snow plough blades, switch off vehicle's engine and remove the key from the ignition.

Excessively worn or damaged blades must be replaced with new ones. Before replacing the blades, raise the machine and support it with stable supports, turn off the engine and immobilise vehicle with parking brake.

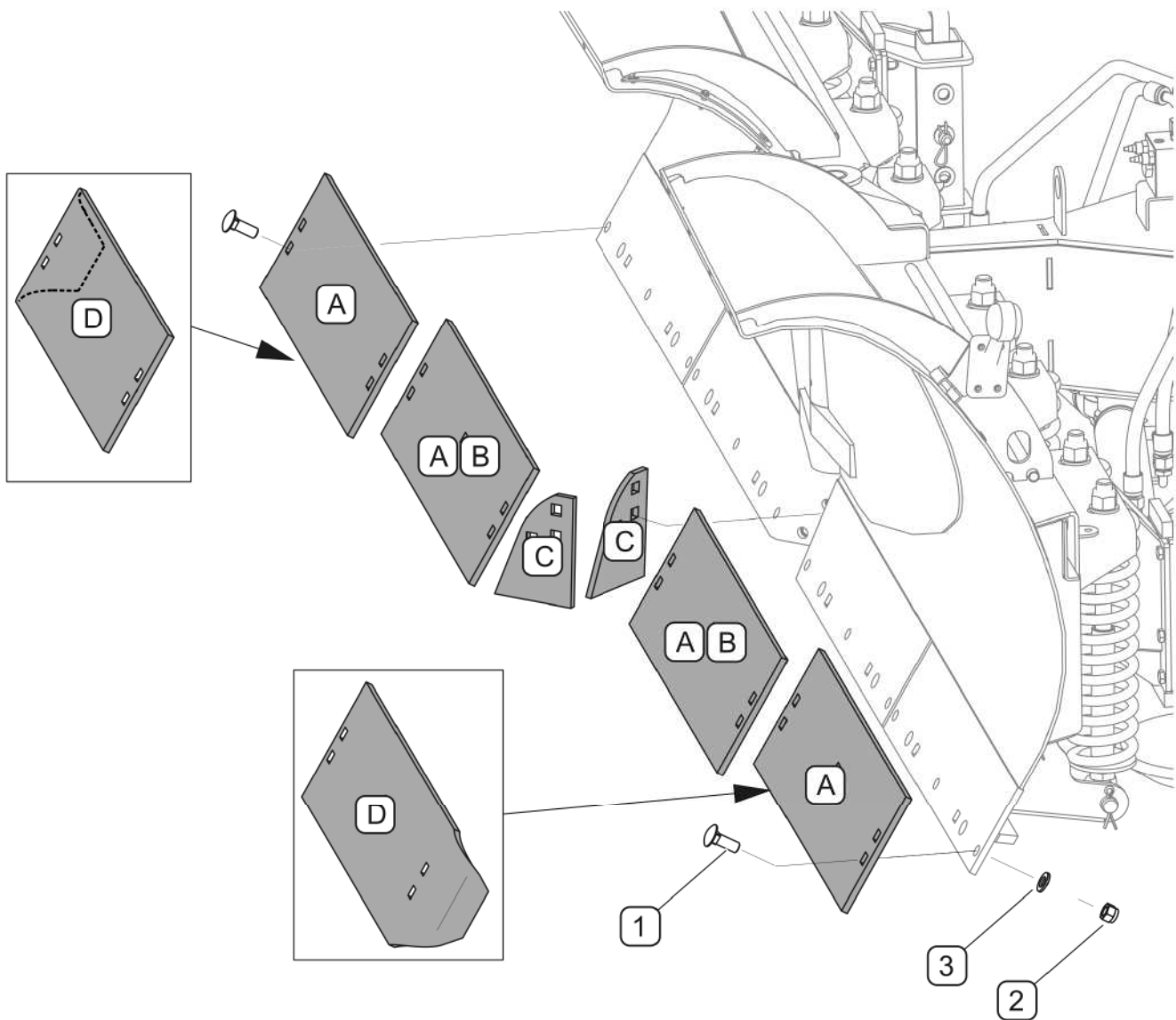

FIGURE 5.1 Replacement of steel blades

(A) - external steel blade; (B) - steel blade; (C) - internal blade; (D) - external steel blade with a bumper (option); (1) - Z M16x50-8.8 bolt; (2) - M16-8 nut; (3) - 16-100HV washer

**DANGER**

Do NOT perform service or repair work under raised and unsupported machine.

Steel blades (FIGURE 5.1) consist of segments. To remove a blade segment, unscrew proper nuts (4), remove bolts (3) that fix the blade segment to the mouldboard. Damaged blade should be replaced. The blades that are worn on one side can be turned on the other side and reused. List of steel blades is shown in (TABLE 5.1).

TABLE 5.1 Steel snow plough blades

Marking FIGURE 5.1	Name / Catalogue No	Quantity [item]
PUV-2600M		
A	External steel blade / 448N-03000001	2
B	Steel blade / 448N-03000002	2
C	Internal blade / 446N-03000002	2
D*	External blade with a bumper / 448N-03000003	2
PUV-2800M		
A	Steel blade / 446N-03000003	4
C	Internal blade / 446N-03000002	2
D*	External blade with a bumper / 446N-03000004	2
PUV-3000M		
A	External steel blade / 453N-03000001	2
B	Steel blade / 446N-03000003	2
C	Internal blade / 446N-03000002	2
D	External blade with a bumper / 453N-03000002	2
PUV-3300M		
A	Steel blade / 452N-03000001	4
C	Internal blade / 446N-03000002	2
D*	External blade with a bumper / 452N-03000002	2

* – used as external blade instead of (A) blade

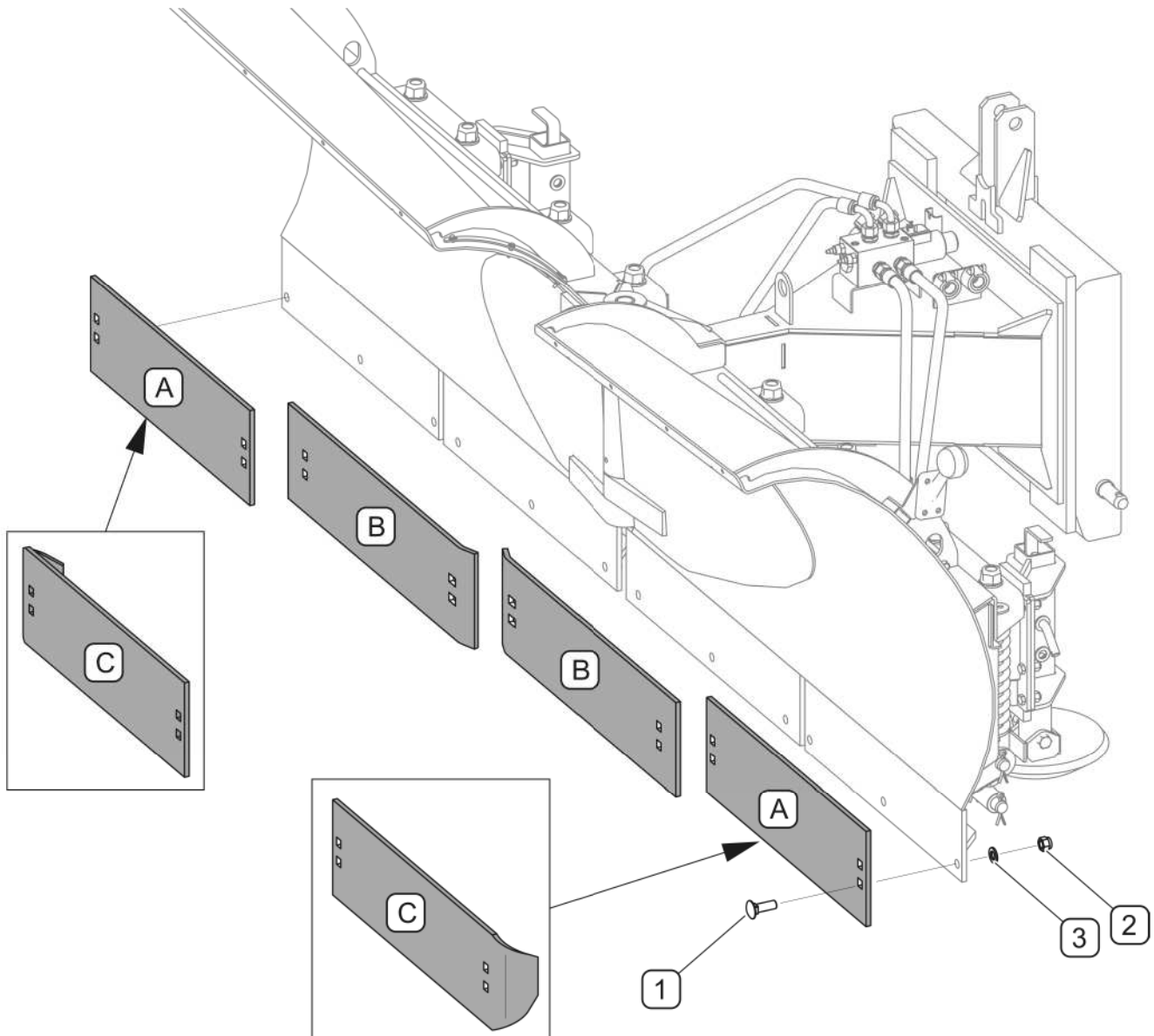

FIGURE 5.2 Replacement of vertical steel blades (option)

(A) - external steel blade; (B) - internal steel blade; (C) - external steel blade with a bumper (option); (1) - Z M16x50-8.8 bolt; (2) - M16-8 nut; (3) - washer 16-100HVA

Optionally, the snow plough can be equipped with vertical steel blades (FIGURE 5.2), perpendicular to the ground. List of vertical steel blades is shown in TABLE 5.2.



ATTENTION

Each time the machine hits an obstacle, technical condition of blades and their mounting should be checked.

TABLE 5.2 Vertical steel blades (option)

Marking FIGURE 5.2	Name / Catalogue No	Quantity [item]
PUV-2600M		
A	External steel blade / 448N-03000001	2
B	Internal steel blade / 448N-08000001	2
C*	External blade with a bumper / 448N-03000003	2
PUV-2800M		
A	External steel blade / 446N-03000003	2
B	Internal steel blade / 448N-09000001	2
C*	External blade with a bumper / 446N-03000004	2
PUV-3000M		
A	External steel blade / 453N-03000001	2
B	Internal steel blade / 446N-09000001	2
C*	External blade with a bumper / 453N-03000002	2
PUV-3300M		
A	Steel blade / 452N-09000001	2
B	Steel blade III / 452N-09000003	2
C*	Steel blade II with a bumper / 452N-09000002	2

* – used as external blade instead of (A) blade

Rubber blades of the snow plough's mouldboards (FIGURE 5.3) consist of external segments and internal segments. To remove blades, unscrew proper nuts (4), remove bolts (3) and remove cover plates (1) and (2). Install new blades and assemble them performing the above activities in reverse sequence. The blades that are worn on one side can be turned on the other side and reused. List of rubber blades is shown in TABLE 5.3

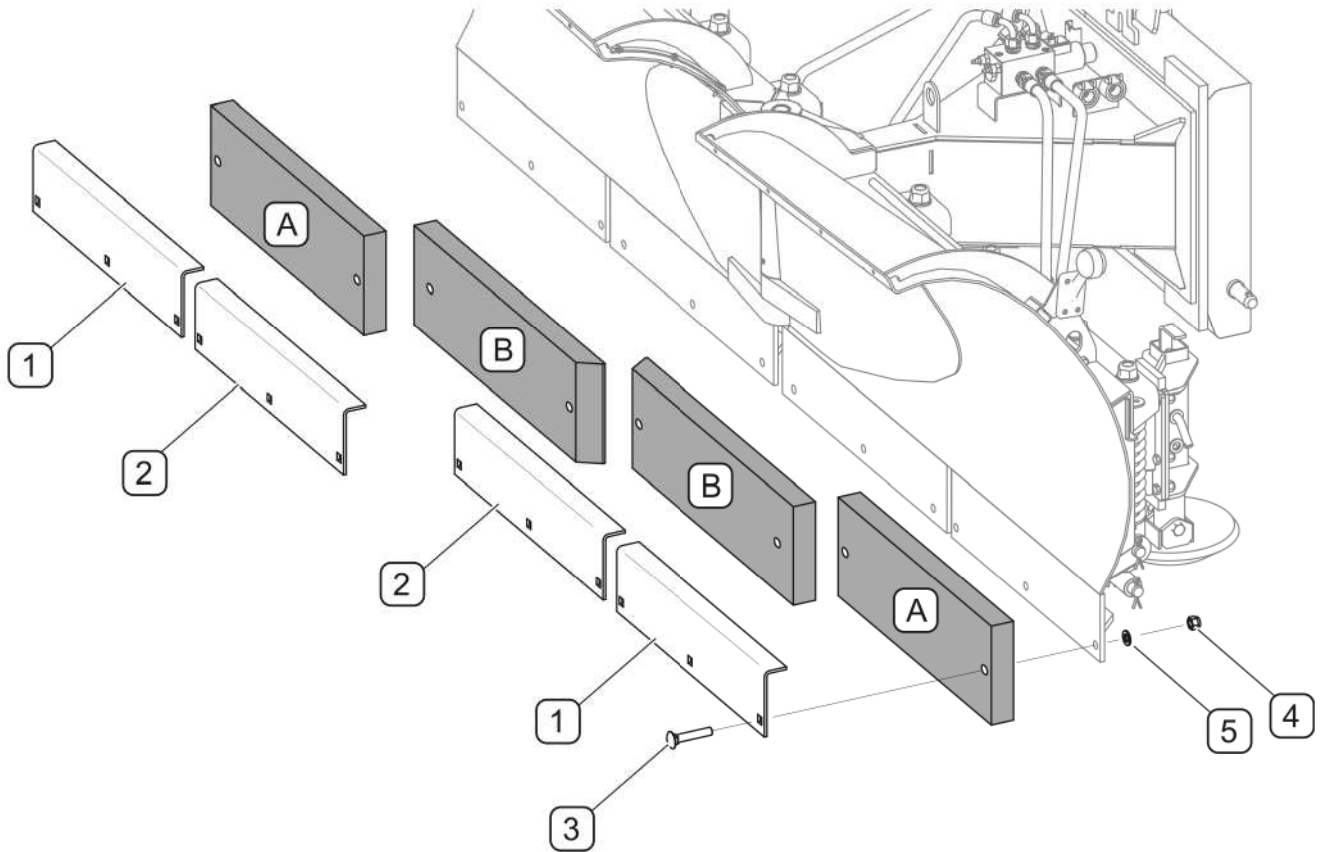

FIGURE 5.3 Replacement of rubber blades

(A) - external blade; (B) - internal blade (1) - external cover plate; (2) - internal cover plate; (3) - Z M16x90-8.8 bolt; (4) - M16-8 nut; (5) - 16-100HV washer

TABLE 5.3 Rubber snow plough blades

Marking FIGURE 5.3	Name / Catalogue No	Quantity [item]
PUV-2600M		
A	External rubber blade / 448N-04000003	2
B	Internal rubber blade / 448N-04000004	2
PUV-2800M		
A	External rubber blade / 446N-04000003	4
B	Internal rubber blade / 446N-04000004	2
PUV-3000M		
A	External rubber blade / 453N-04000002	2
B	Internal rubber blade / 446N-04000004	2
PUV-3300M		
A	External rubber blade / 452N-04000003	2
B	Internal rubber blade / 452N-04000002	2

5.2 SLIDE REPLACEMENT

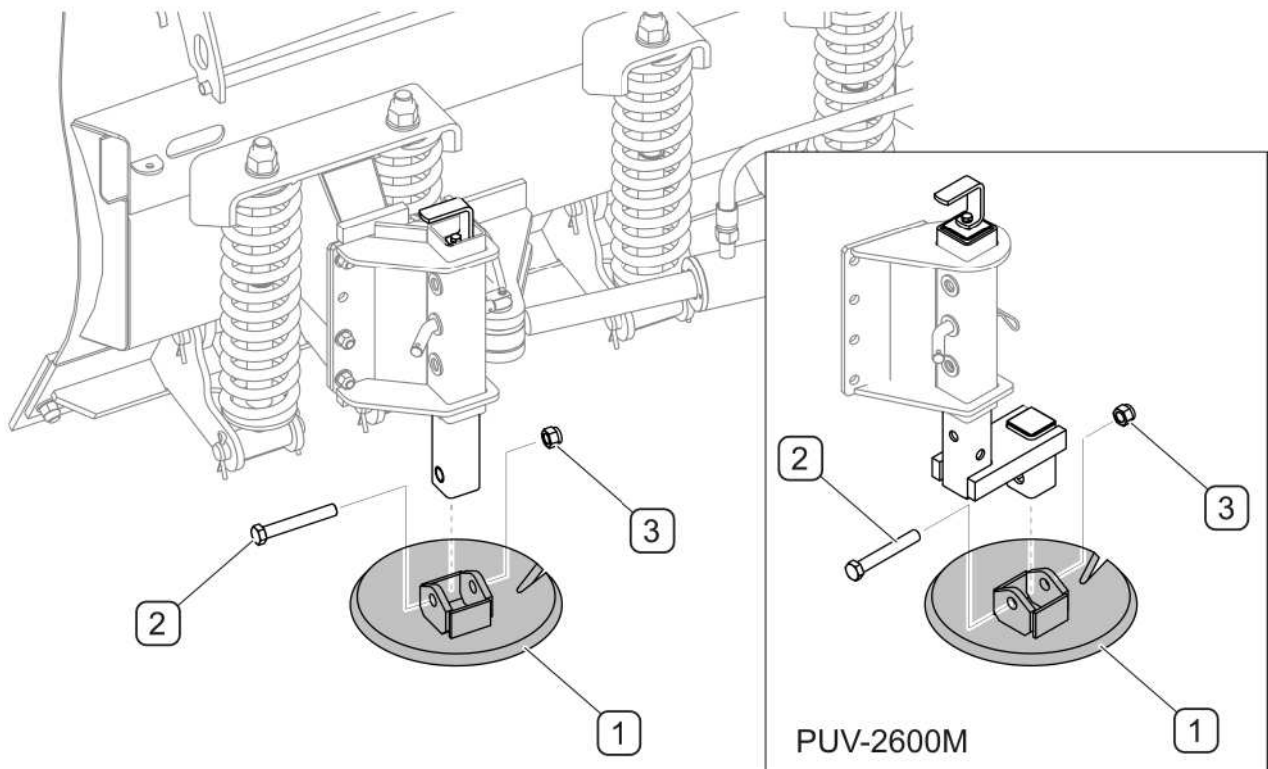

FIGURE 5.4 Slide replacement

(1) - slide; (2) - M16x110-8.8 bolt; (3) - M16-8 nut

Excessively worn or damaged slide elements (FIGURE 5.4) must be replaced with new ones. In order to do this raise the plough and support with sufficiently stable and strong supports. If the plough is hitched and raised on the front three-point linkage, protect it from falling and immobilise the tractor (turn off the engine and engage the parking brake.) Undo nut (3), remove bolt (2) fixing the slide (1) with a slider. Check the slide (1) and other elements for damage or excessive wear. The list of slide working components including catalogue numbers is shown in TABLE 5.4

TABLE 5.4 A list of slide components

Marking FIGURE 5.4	Name / Catalogue No.	Quantity [item]
1	Slide / 126N-05010000	1
2	Bolt M16x110-8,8-A2J PN-EN ISO 4014	1
3	Self locking nut M16-8-A2J PN-EN ISO 7040	1

Quantities of parts for one slide are given in the table.

5.3 ADJUSTMENT OF COLLECTING BLADE SPRINGS



DANGER

Adjustment of collecting blade springs should be performed only when the engine is stopped, and the machine is raised and secured.

The snow plough is equipped with swinging segments of collecting blades. When an obstacle is encountered, individual segments of collecting blades (FIGURE 5.5) can independently swing backward and return to working position thanks to shock absorbing springs. Inclination of blades and tension of springs can be adjusted. Blade segment inclination angle is adjusted using nut (1) while spring (4) tension can be adjusted using nut (2) after loosening counter nut (3).

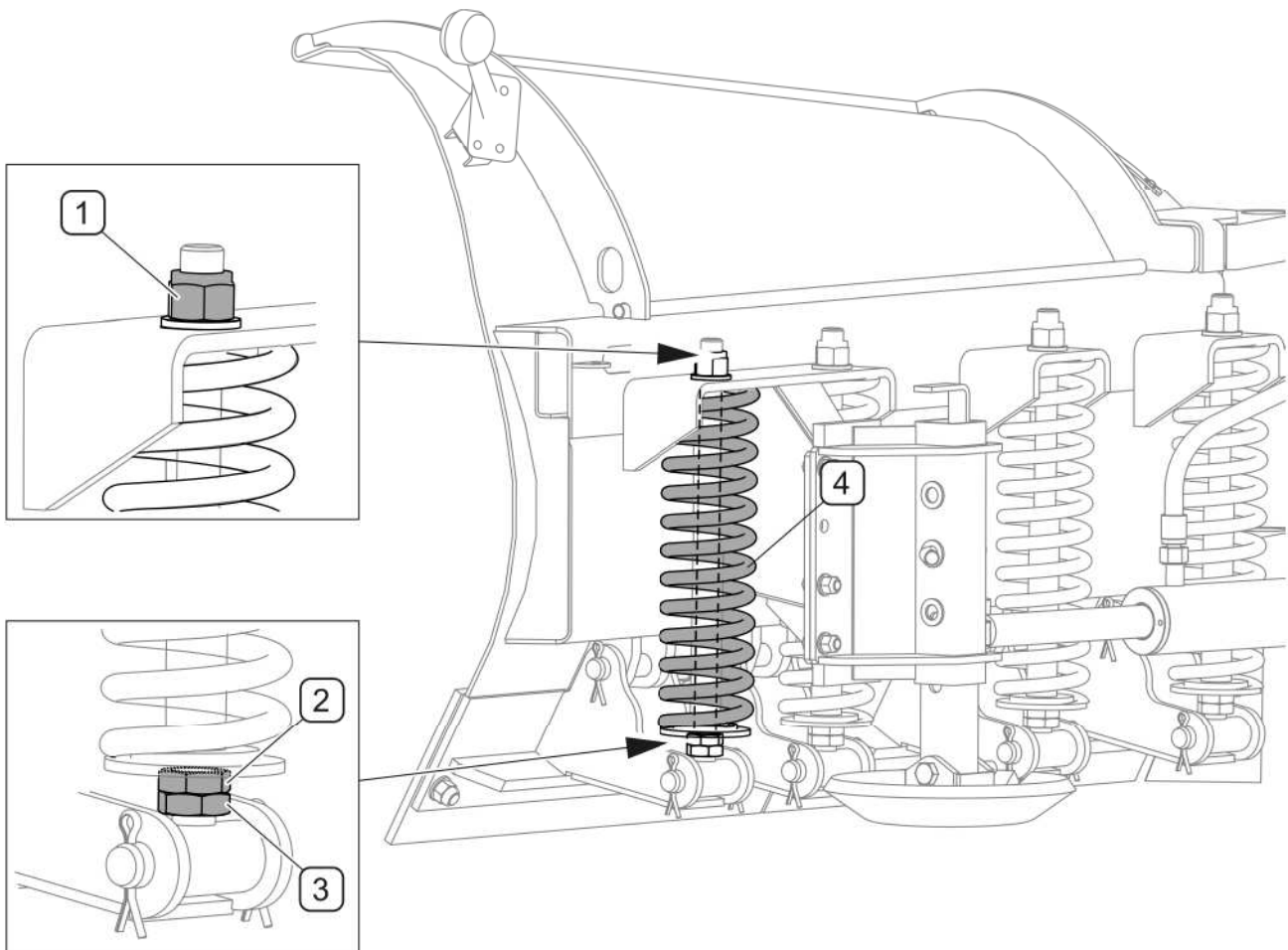

FIGURE 5.5 Adjustment of collecting blades

(1) - blade inclination adjusting nut; (2) - blade spring tension adjusting nut; (3) - counter-nut;
(4) - spring

**TIP**

During the adjustment, set the collecting blades in such a manner as to ensure that front surfaces of individual blade segments form a single plane.

5.4 HYDRAULIC SYSTEM OPERATION

The duties of the operator connected with the hydraulic system include:

- checking tightness of cylinders hydraulic connections,
- checking technical condition of hydraulic lines;
- checking technical condition and leak tightness of hydraulic connectors

**DANGER**

Do not repair hydraulic system on your own. All hydraulic system repairs must be performed only by suitably qualified personnel.

**ATTENTION**

Before you begin, visually inspect the hydraulic system components.

Because of its composition, the oil in the hydraulic system is not classified as a dangerous substance, however long-term action on the skin or eyes may cause irritation. In the event of contact of oil with skin wash the place of contact with water and soap. Do NOT apply organic solvents (petrol, kerosene). Contaminated clothing should be changed to prevent access of oil to skin. In the event of contact of oil with eye, rinse with large quantity of water and in the event of the occurrence of irritation consult a doctor. Hydraulic oil in normal conditions is not harmful to the respiratory tract. A hazard only occurs when oil is strongly atomised (oil vapour), or in the case of fire during which toxic compounds may be released.

**DANGER**

Oil fires should be quenched with carbon dioxide (CO₂), foam or extinguisher steam. Do NOT use water for fire extinguishing!

TABLE 5.5 HL32 HYDRAULIC OIL CHARACTERISTICS

ITEM	NAME	VALUE
1	ISO 3448VG viscosity classification	32
2	Kinematic viscosity at 40°C	28.8 – 35.2 mm ² /s
3	ISO 6743/99 quality classification	HL
4	DIN 51502 quality classification	HL
5	Flash point, °C	Above 210°C
6	Maximum operating temperature, °C	80



DANGER

During work on hydraulic systems use the appropriate personal protection equipment i.e. protective clothing, footwear, gloves and eye protection. Avoid contact of skin with oil.

Spilt oil should be immediately collected and placed in marked tight container. Used oil should be taken to the appropriate facility dealing with the re-use of this type of waste.

The machine's hydraulic system should be completely tight sealed. Inspect the seals when hydraulic cylinders are completely extended. In the event of confirmation of oil on hydraulic cylinder bodies ascertain origin of leak. Minimum leaks are permissible with symptoms of "sweating", however in the event of noticing leaks in the form of "droplets" stop using the machine until faults are remedied.



DANGER

Before commencing whatever work on hydraulic system reduce the residual pressure in the system.



The condition of hydraulic system should be inspected regularly while using the machine.

In the event of confirmation of an oil leak on hydraulic line connections, tighten connections, and if this does not remedy faults then change line or connection elements. Change of sub-

assemblies is equally required in each instance of mechanical damage.

**ATTENTION**

The hydraulic system is vented automatically during machine operation.

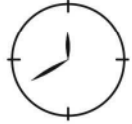

Rubber hydraulic conduits should be replaced after 4 years of machine use.

5.5 ELECTRICAL SYSTEM MAINTENANCE

Electrical system maintenance involves periodical checking the operation of the lighting system and hydraulic solenoid valves. After hitching the machine to the carrying vehicle, connect power lead of the electrical system and the switch wiring harness. Connect hydraulic conduits to the connectors of the carrying vehicle's external hydraulic system. Check operation of clearance lights and individual functions of the machine.

**DANGER**

Do not independently repair electrical system, except items described in chapter **ELECTRICAL SYSTEM MAINTENANCE**. All electrical system repairs must be performed only by suitably qualified personnel.

The snow plough's clearance lights are maintenance-free LED lights.

5.6 LUBRICATION

Machine lubrication should be performed with the aid of a manually or foot operated grease gun, filled with generally available permanent grease. Before commencing lubrication insofar as is possible remove old grease and other contamination. Remove and wipe off excess oil or grease ŁT-43-PN/C-96134 grease is recommended for lubrication.

	<p>DANGER</p> <p>Lubrication may only be performed when plough is lowered, and resting on the ground. Before lubricating, switch off engine, remove key from ignition and engage carrying vehicle brake.</p>
---	---

TABLE 5.6 LUBRICATION POINTS AND LUBRICATION FREQUENCY

ITEM	NAME	NUMBER OF LUBRICATI ON POINTS	TYPE OF GREASE	LUBRICATION FREQUENCY
A	Blade main pivot pin	4	grease	50 hours
B	Linkage skid plate	2		20 hours
C	Wheel column bolt (option)	2		50 hours
D	Wheel bearing (option)	2		10 hours
E	Hydraulic cylinder eye	2+2		50 hours

Marking description in Item column (TABLE 5.6) conforms with numbering shown (FIGURE 5.6)

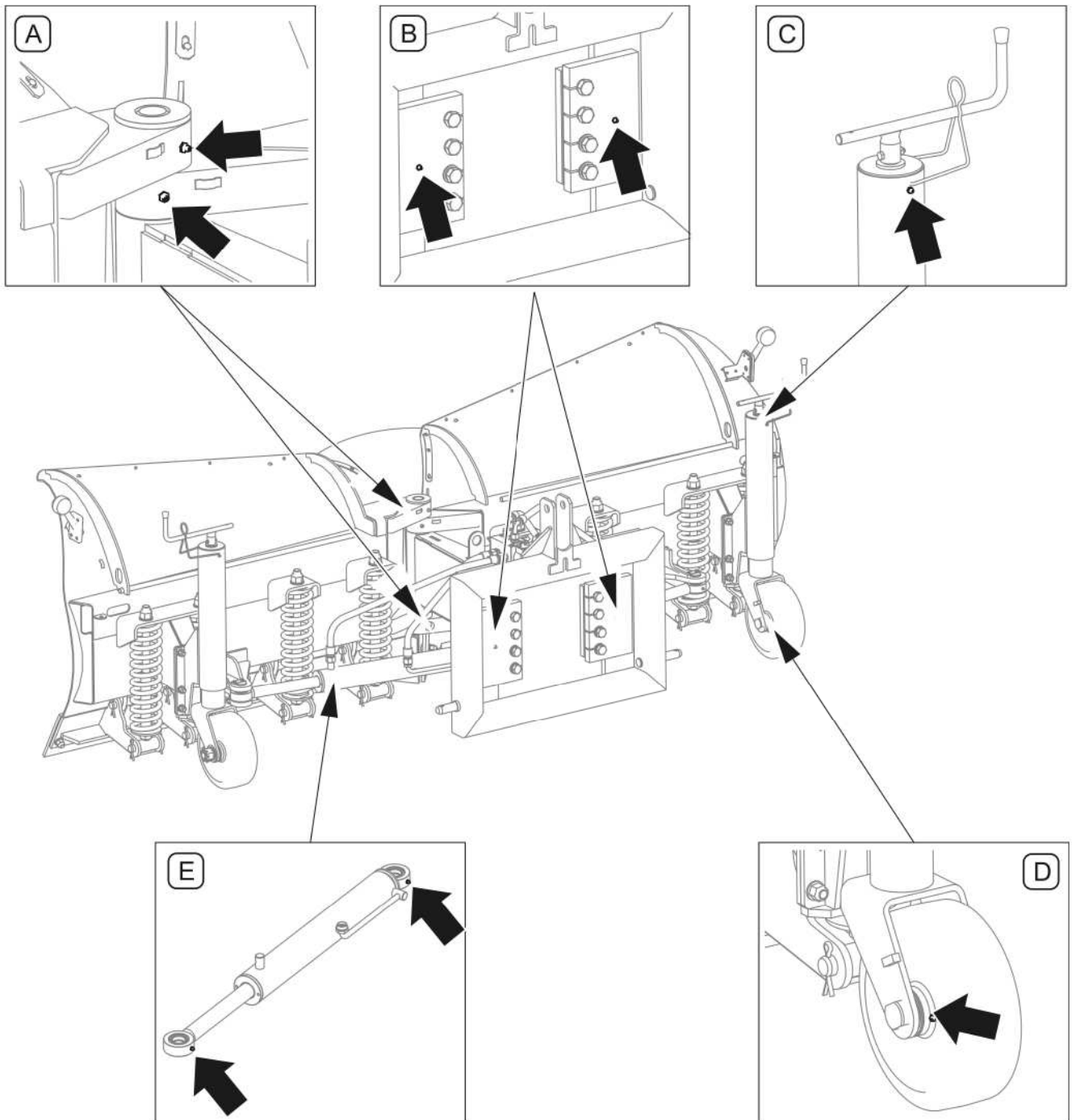

FIGURE 5.6 Lubrication points

Lubrication points are described in TABLE 5.8



When using the machine the user is obliged to observe lubrication instructions according to attached schedule. Excess lubrication substance causes depositing additional contaminants in places requiring lubrication, therefore it is essential to keep individual machine elements clean.

5.7 STORAGE

After finishing work, machine should be thoroughly cleaned and washed with water jet. While washing, do not direct a strong water or steam jet at information and warning decals or hydraulic lines and electrical components. Nozzle of pressure or steam washer should be kept at a distance of not less than 30 cm from cleaned surface.

After cleaning, inspect the whole machine, inspect technical condition of individual elements. Used or damaged elements should be repaired or replaced.

In the event of damage to the paint coat, clean rust and dust from damaged area, degrease and then paint with undercoat and after it is dry paint with surface coat paint retaining colour uniformity and even thickness of protective coating. Until the time of touch-up painting, the damaged place may be covered with a thin layer of grease or anticorrosion preparation. Machine should be kept in closed or roofed building.

If the machine shall not be used for a long period of time, protect it against adverse weather conditions. Lubricate machine according to the instructions provided. In the event of prolonged work stoppage, it is essential to lubricate all elements regardless of the period of the last lubrication process.

Machine disconnected from the carrying vehicle should be placed on parking stands, on level, sufficiently hard surface in such a manner as to ensure that it is possible to connect it again.

The switch with the solenoid valve power lead and the connecting cable of clearance lights should be disconnected from the machine and protected against adverse weather conditions.

5.8 TIGHTENING TORQUE FOR NUT AND BOLT CONNECTIONS

During maintenance and repairs use appropriate torque for bolt connections (unless other is specified for a particular connection). Recommended bolt tightening torque values are given in TABLE 5.7.



ATTENTION

Should it be necessary to change individual parts, use only original parts or those indicated by the Manufacturer. Non-adherence to these requirements may put the user and other people's health and life at risk, and also damage the machine.

TABLE 5.7 TIGHTENING TORQUE FOR NUT AND BOLT CONNECTIONS

THREAD DIAMETER [mm]	5.8	8.8	10.9
	TIGHTENING TORQUE [Nm]		
M6	8	10	15
M8	18	25	36
M10	37	49	72
M12	64	85	125
M14	100	135	200
M16	160	210	310
M20	300	425	610
M24	530	730	1 050
M27	820	1,150	1,650

The tightening torque values given in the table apply to non-greased steel bolts.

5.9 TROUBLESHOOTING

TABLE 5.8 TROUBLESHOOTING

TYPE OF FAULT	CAUSE	REMEDY
Mouldboard position cannot be changed	The electrical system is not connected to the carrying vehicle	Connect it to the carrying vehicle's electrical system
	The hydraulic system is not connected to the carrying vehicle	Connect hydraulic quick-couplers to a proper section of the carrying vehicle's hydraulic system.
	Control switch is not connected	Connect control switch to electrical lead
	Damaged fuse on power lead	Check and, if necessary, replace the fuse in the power lead in the carrying vehicle (if installed)
	The machine hydraulic system is damaged	Repair at an authorised service point
Machine scoops snow unevenly	Incorrectly positioned wheels (option)	Check and adjust according to operator's manual
	Excessively worn collecting plough blades	Check and replace if necessary
No lighting	Electrical system not connected.	Connect electrical system to carrying vehicle. Check connections on electric leads.
	Damaged clearance lamp	Replace
	The machine electrical system is damaged	Repair at an authorised service point

NOTES

A series of horizontal dotted lines for writing notes.